



# COMBITHERM®

## Combination Oven/Steamer



### CT PROFORMANCE™

CTP6-10E	CTP6-10G
CTP10-10E	CTP10-10G
CTP7-20E	CTP7-20G
CTP10-20E	CTP10-20G
CTP20-10E	CTP20-10G
CTP20-20E	CTP20-20G

### CT CLASSIC™

CTC6-10E	CTC6-10G
CTC10-10E	CTC10-10G
CTC7-20E	CTC7-20G
CTC10-20E	CTC10-20G
CTC20-10E	CTC20-10G
CTC20-20E	CTC20-20G

**⚠ WARNING**

To prevent personal injury, death or property damage:

**Do not** store or use gasoline or other flammable vapors or liquids in the vicinity of this or any other appliance.

**⚠ WARNING**

Improper installation, alteration, adjustment, service, cleaning, or maintenance could result in property damage, severe injury, or death.

Read and understand the installation, operating and maintenance instructions thoroughly before installing, servicing, or operating this equipment.





All Alto-Shaam equipment is sold Free on Board (F.O.B.) shipping point, and when accepted by the carrier, such shipments become the property of the consignee.

Should damage occur in shipment, do not put the appliance into service until the damage has been inspected by an authorized Alto-Shaam service provider.

Shipping damages are a matter between the carrier and the consignee. In such cases, the carrier is assumed to be responsible for the safe delivery of the merchandise, unless negligence can be established on the part of the shipper.

1. Make an immediate inspection while the appliance is still in the truck or immediately after it is moved to the receiving area. Do not wait until after the appliance is moved to a storage area.
2. Do not sign a delivery receipt or a freight bill until a proper count has been made and inspection of all appliances are received.

3. Note all damage to packages directly on the carrier's delivery receipt.
4. Make certain the driver signs the delivery receipt. If the driver refuses to sign, make a notation of this refusal on the receipt.
5. If the driver refuses to allow inspection, write the following on the delivery receipt: **Driver refuses to allow inspection of containers for visible damage.**
6. Contact the carrier's office immediately upon finding damage, and request an inspection. Mail a written confirmation to the carrier's office with the time, date, and the person called.
7. Save any packages and packing material for further inspection by the carrier.
8. Promptly file a written claim with the carrier and attach copies of all supporting paperwork.

Alto-Shaam will continue our policy of assisting our customers in collecting claims which have been properly filed and actively pursued. Alto-Shaam cannot, however, file any damage claims, assume the responsibility of any claims, or accept deductions in payment for such claims.

Record the model and serial number of the appliance for easy reference. Always refer to both model and serial number in any contact with Alto-Shaam regarding this appliance.

Model: \_\_\_\_\_

Serial Number: \_\_\_\_\_

Date Installed: \_\_\_\_\_

Voltage: \_\_\_\_\_

Purchased From: \_\_\_\_\_

\_\_\_\_\_  
\_\_\_\_\_



**Alto-Shaam has established a twenty-four hour emergency service call center to offer immediate customer access to a local authorized service agency outside of standard business hours. The emergency service access is provided exclusively for Alto-Shaam equipment and is available throughout the United States through the use of Alto-Shaam's toll-free number. Emergency service access is available seven days a week including holidays.**

## DELIVERY

This Alto-Shaam appliance has been thoroughly tested and inspected to ensure only the highest quality unit is provided. Upon receipt, check for any possible shipping damage and report it at once to the delivering carrier. See **Transportation Damage and Claims** section located in this manual.

This appliance, complete with unattached items and accessories, may be delivered in one or more packages. Ensure all standard items and options have been received with each model as ordered.

Save all the information packed with the appliance. Register online at [www.alto-shaam.com](http://www.alto-shaam.com) to ensure prompt service in the event of a warranty parts and labor claim.

This manual must be read and understood by all people using or installing the equipment model. Contact the Alto-Shaam Tech Team if you have any questions concerning installation, operation, or maintenance.

1-800-558-8744; servicedept@alto-shaam.com

### The serial number is required for all inquiries.

Always include both model and serial number(s) in any correspondence regarding the appliance.

**Model:** \_\_\_\_\_

**Serial number:** \_\_\_\_\_

**Purchased from:** \_\_\_\_\_

**Date installed:** \_\_\_\_\_ **Voltage:** \_\_\_\_\_

## UNPACKING

- Carefully remove the appliance from the carton or crate.

**NOTICE:** Do not discard the carton and other packaging material until you have inspected the unit for hidden damage and tested it for proper operation.

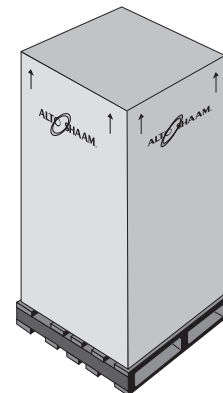

- Read all instructions in this manual carefully before installing this appliance, using the appliance, or performing routine maintenance. Following procedures other than those indicated in this guide to use and clean the appliance is considered inappropriate and may cause damage, injury, or fatal accidents, in addition to invalidating the guarantee and relieving Alto-Shaam of all liability.
- DO NOT DISCARD THIS MANUAL.** This manual is considered part of the appliance and is provided for the owner or manager of the business and for training personnel. Additional manuals are available from the Alto-Shaam Tech Team, or online at [www.alto-shaam.com](http://www.alto-shaam.com).
- Remove all protective plastic film, packaging materials, and accessories from the appliance before connecting electrical power. Store any accessories in a convenient place for future use.



## CAUTION



Appliance and accessories may be heavy. To prevent injury, **always** use a sufficient number of trained and experienced workers when moving or leveling appliance and handling accessories.

## OPERATIONAL ENVIRONMENTAL CONDITIONS

- Unit must acclimate to room temperature in the environment it is placed. 24 hours is recommended.
- Ambient temperature range of 60°F to 110°F (16°C to 43°C).
- Relative humidity of less than 95% non-condensation.
- Atmospheric pressure range of 50KPa to 106KPa.

This manual covers the following CTC and CTP series models:

Control Type		Boiler-Free Models	Steam Generator Models
CTP	CT PROformance™ with PROtouch™ control	6-10E, 6-10G 10-10E, 10-10G	6-10EB 10-10EB
CTC	CT Classic with Classic manual control	7-20E, 7-20G 10-20E, 10-20G 20-10E, 20-10G 20-20E, 20-20G	7-20EB 10-20EB 20-10EB 20-20EB

Please post the following instructions in a prominent location in the event the user smells gas.

**DANGER**



Explosion hazard. Before starting the appliance, make certain you do not detect the odor of gas.

If you smell gas:

- Shut off the gas supply immediately.
- Do not attempt to light any appliance.
- Do not touch any electrical elements.
- Extinguish any open flame.
- Evacuate the area.
- Use a telephone outside the property and immediately contact your gas supplier.
- If unable to contact your gas supplier, contact the fire department.

<b>Transporation Damage and Claims</b> . . . . .	<b>2</b>	<b>CT PROformance™ Start-Up Procedures</b> . . . . .	<b>45</b>
<b>Delivery</b> . . . . .	<b>3</b>	How To Turn On the Appliance . . . . .	45
<b>Table of Contents</b> . . . . .	<b>5</b>	How To Start a Manual Calibration . . . . .	45
<b>Safety Procedures and Precautions</b> . . . . .	<b>6</b>	How To Calibrate the Touchscreen . . . . .	45
<b>Labels</b> . . . . .	<b>8</b>	How To Turn Off the Appliance . . . . .	45
<b>Installation Codes and Standards</b> . . . . .	<b>15</b>	How To Run a Cycle Test of the Appliance . . . . .	46
Site Installation . . . . .	15	<b>CT Classic™ Start-Up Procedures</b> . . . . .	<b>47</b>
Installation Codes and Standards . . . . .	15	How To Turn On the Appliance . . . . .	47
Ventilation Requirements . . . . .	15	How To Run a Cycle Test of the Appliance . . . . .	47
Sound Pressure Measurements . . . . .	15	<b>Inspection Checklist</b> . . . . .	<b>48</b>
<b>Technical Specifications</b> . . . . .	<b>16</b>	<b>Troubleshooting – Error Codes</b> . . . . .	<b>54</b>
General Specifications . . . . .	16	Error Codes . . . . .	54
Oven Specifications . . . . .	17	Touch Motor Control Error Codes . . . . .	59
<b>Installation</b> . . . . .	<b>20</b>		
Lifting Instructions . . . . .	20		
Positioning on Site – Countertop Models . . . . .	21		
Positioning on Site – 20-10 & 20-20 Models . . . . .	22		
Electrical Safety Regulations . . . . .	23		
Electrical Connection for Gas Models . . . . .	24		
Electrical Connection for Electric Models . . . . .	24		
Electrical Kit Installation – 50 Hz (Rear Panel with Cover Plates) . . . . .	25		
Electrical Kit Installation – 50 Hz . . . . .	26		
Electrical Kit Installation – 60 Hz (Rear Panel with Cover Plates) . . . . .	27		
Electrical Kit Installation – 60 Hz . . . . .	28		
Ventilation Requirements for Gas Models . . . . .	29		
Gas Supply & Installation . . . . .	30		
Water Quality Requirements . . . . .	35		
Water Supply & Installation . . . . .	36		
Water Drainage – For Single Oven . . . . .	37		
Water Drainage – For Single Oven (Rear Panel with Louver) . . . . .	38		
Water Drainage – For Stacked Ovens . . . . .	39		
Water Drainage – For Stacked Ovens (Rear Panel with Louver) . . . . .	40		
Mobile Equipment Restraint . . . . .	41		
For Gas Models . . . . .	41		
For Electric Models . . . . .	41		
Special Conditions for Units Installed within the City of New York . . . . .	42		
Liquid Cleaner Hook-Up (If Equipped with this Option) . . . . .	43		
Grease Collection Installation (If Equipped with this Option) . . . . .	44		

- This appliance is intended to cook, hold, or process foods for the purpose of human consumption. No other use for this appliance is authorized and is therefore considered dangerous. The appliance must not be used to cook food containing flammable materials (such as food with alcohol). Substances with a low flash point can ignite spontaneously and cause a fire.
- This appliance is intended for use in commercial establishments where all operators are familiar with the purpose, limitations, and associated hazards of this appliance. Operating instructions and safety alerts must be read and understood by all operators and users. We recommend regular training of your staff to avoid the risk of accident or damage to the unit. Operators must also receive regular safety instructions.
- Any troubleshooting guides, component views, and parts lists included in this manual are for general reference only and are intended for use by qualified and trained technicians.
- This manual should be considered a permanent part of this appliance. This manual and all supplied instructions, diagrams, schematics, parts lists, notices, and labels must remain with the appliance if the item is sold or moved to another location.

Knowledge of proper procedures is essential to the safe operation of electrically and/or gas energized equipment. The following signal words and symbols may be used throughout this manual.

## **DANGER**

Indicates a hazardous situation that, if not avoided, will result in death or serious injury.

## **WARNING**

Indicates a hazardous situation that, if not avoided, could result in death or serious injury.

## **CAUTION**

Indicates a hazardous situation that, if not avoided, could result in minor or moderate injury.

**NOTICE:** Indicates information considered important, but not hazard-related (e.g., messages relating to property damage).

**NOTICE:** For equipment delivered for use in any location regulated by the following directive: 2012/95/EC WEEE



DO NOT dispose of electrical or electronic equipment with other municipal waste.

- To prevent serious injury, death, or property damage, your appliance should be inspected and serviced at least every twelve (12) months by an authorized service partner or trained technician.
- ONLY allow an authorized service partner or trained technician to service or to repair your appliance. Installation or repairs that are not performed by an authorized service partner or trained technician, or the use of non-factory authorized parts, will void the warranty and relieve Alto-Shaam of all liability.
- When working on this appliance, observe precautions in the literature, on tags, on labels attached to or shipped with the appliance, and other safety precautions that may apply.
- If the appliance is installed on casters, freedom of movement of the appliance must be restricted so that utility connections (including gas, water, and electricity) cannot be damaged when the unit is moved. If the appliance is moved, make sure that all utility connections are properly disconnected. If the unit is returned to its original position, make sure that any retention devices and utility connections are properly connected.
- ONLY use the appliance when it is stationary. Mobile oven racks, mobile plate racks, transport trolleys, and appliances on casters can tip over when being moved over an uneven floor or threshold and cause serious injury.
- ALWAYS apply caster brakes on mobile appliances or accessories when these are not being moved. These items could move or roll on uneven floors and cause property damage or serious injury.
- Be extremely careful when moving appliances because the food trays may contain hot fluids that may spill, causing serious injury.
- ALWAYS open the appliance door very slowly. Escaping hot vapors or steam can cause serious injury or death.
- If your gas appliance is installed under an exhaust hood, the hood must be switched ON when the oven is in use to avoid the buildup of combustion gases. Failure to do so may result in serious injury, death, or property damage.
- NEVER place objects near the oven exhaust vents. This area is hot and could be a potential ignition source for a fire.
- Do not allow objects to block or obstruct the area below the oven base. This may result in fire, damage to the equipment, or serious injury.
- Do not use the attached hand-held hose to spray anything other than the interior of the oven compartment.
- Do not use the attached hand-held hose on the surface of a hot cooking compartment. The sudden temperature change can damage the oven interior. Allow the oven to cool to a minimum of 150°F (66°C). Failure to observe this precaution can void the warranty.



## WARNING



This appliance is not intended for use by persons (including children) with reduced physical, sensory or mental capabilities, or lack of experience and knowledge, unless they have been given supervision concerning use of the appliance by person responsible for their safety.

Children should be supervised to ensure that they do not play with the appliance.











## WARNING







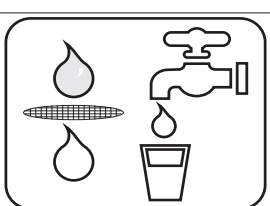











**DO NOT** obstruct or block exhaust flues or attach any flue extension that may impede proper burner operation, restrict the exhaust fumes and cause negative backdraft or the appliance to shut down. Failure to do so may result in serious injury or death.

	<p>Made in U.S.A.</p>
	<p>WARNING Hot surface</p>
	<p>WARNING Electric shock hazard</p>
	<p>WARNING Burn hazard Always load liquids, or foods that can become liquid when heated, at an eye level where they can be seen.</p>
	<p>Every Alto-Shaam product is precision calibrated prior to release from the factory to ensure accurate temperature control.</p>

 <p>LA-36443-L1</p>	<p>Line 1 supply terminal</p>
 <p>LA-36443-L2</p>	<p>Line 2 supply terminal</p>
 <p>LA-36443-L3</p>	<p>Line 3 supply terminal</p>
 <p>LA-36443-L2/N</p>	<p>Neutral</p>
 <p>LA-36443-G</p>	<p>Ground terminal</p>
 <p>LA-36443-E</p>	<p>Equipotential terminal</p>
 <p>LA-38911</p>	<p>Drain water connection point.</p>
 <p>LA-38910</p>	<p>Untreated, drinkable water connection point.</p>
 <p>LA-38909</p>	<p>Treated, drinkable water connection point.</p>

<div style="display: flex; align-items: center; justify-content: space-around;"> </div> <table border="1" style="width: 100%; border-collapse: collapse; text-align: center;"> <thead> <tr> <th></th> <th>Σ kg max.</th> <th>Σ liter max.</th> <th>Σ GN 1/1</th> </tr> </thead> <tbody> <tr> <td>6-10</td> <td>33</td> <td>57</td> <td>6</td> </tr> <tr> <td>10-10</td> <td>54</td> <td>95</td> <td>10</td> </tr> <tr> <td>7-20</td> <td>76</td> <td>133</td> <td>14</td> </tr> <tr> <td>10-20</td> <td>109</td> <td>190</td> <td>20</td> </tr> <tr> <td>20-10</td> <td>109</td> <td>190</td> <td>20</td> </tr> <tr> <td>20-20</td> <td>218</td> <td>380</td> <td>40</td> </tr> </tbody> </table> <p style="text-align: right; font-size: small;">LA-38940</p>		Σ kg max.	Σ liter max.	Σ GN 1/1	6-10	33	57	6	10-10	54	95	10	7-20	76	133	14	10-20	109	190	20	20-10	109	190	20	20-20	218	380	40	<h3>Capacities</h3>
	Σ kg max.	Σ liter max.	Σ GN 1/1																										
6-10	33	57	6																										
10-10	54	95	10																										
7-20	76	133	14																										
10-20	109	190	20																										
20-10	109	190	20																										
20-20	218	380	40																										
<div style="border: 1px solid black; padding: 5px;"> <div style="background-color: #f96; padding: 2px; display: flex; align-items: center;"> <span style="margin-left: 5px;"><b>WARNING/ADVERTENCIA/AVERTISSEMENT</b></span> </div> <div style="margin-top: 10px;"> <p><b>Fire Hazard</b> This unit is only for use with factory-supplied legs, casters, or base.</p> </div> <div style="margin-top: 10px;"> <p><b>Peligro de incendio</b> This unit is only for use with factory-supplied legs, casters, or base.</p> </div> <div style="margin-top: 10px;"> <p><b>Risque d'incendie</b> This unit is only for use with factory-supplied legs, casters, or base.</p> </div> <p style="text-align: right; font-size: x-small;">LA-39335</p> </div>	<h3>Fire hazard</h3> <p>This unit is only for use with factory-supplied legs, casters, or base.</p> <p>Read the installation manual.</p>																												
<div style="border: 2px solid black; padding: 10px;"> <div style="display: flex; justify-content: space-between; align-items: center;"> </div> <div style="display: flex; justify-content: space-around; margin-top: 10px;"> <div style="text-align: center;"> </div> <div style="text-align: center;"> </div> </div> <div style="display: flex; justify-content: space-around; margin-top: 10px;"> <div style="text-align: center;"> </div> <div style="text-align: center;"> </div> </div> <p style="text-align: right; font-size: x-small;">LA-39336</p> </div>																													

<div data-bbox="126 243 474 359" style="background-color: #f4a460; padding: 5px;">  <b>WARNING ADVERTENCIA AVERTISSEMENT</b> </div> <div data-bbox="136 396 261 512" style="border: 1px solid black; padding: 5px;">  </div> <div data-bbox="272 373 474 594" style="padding: 5px;"> <p>Steam Open carefully.</p> <p>Vapor Abrir con cuidado.</p> <p>Vapeur Ouvrir avec précaution.</p> </div> <div data-bbox="152 573 240 594" style="font-size: small;"> <p>LA-39122</p> </div>	<p>Warning</p> <p>Steam. Open door carefully.</p>
<div data-bbox="110 646 407 905" style="border: 2px solid black; padding: 10px;">  </div>	
<div data-bbox="136 953 228 1045" style="border: 1px solid black; padding: 5px;">  </div> <div data-bbox="289 947 370 1024" style="border: 1px solid black; padding: 5px;">  </div> <div data-bbox="396 947 630 1024" style="background-color: #f4a460; padding: 5px;"> <b>WARNING ADVERTENCIA AVERTISSEMENT</b> </div> <div data-bbox="136 1058 228 1150" style="border: 1px solid blue; border-radius: 50%; padding: 5px;">  </div> <div data-bbox="136 1163 228 1255" style="border: 1px solid blue; border-radius: 50%; padding: 5px;">  </div> <div data-bbox="261 1041 630 1182" style="padding: 5px;"> <p>Failure to follow cleaning instructions can cause injury or equipment damage. Clean oven only with Combitherm cleaner. Cleaner is caustic. Avoid contact with skin or eyes. Wear PPE. Read and understand the Combitherm cleaner safety data sheet and the operator's manual before cleaning.</p> </div> <div data-bbox="261 1199 630 1356" style="padding: 5px;"> <p>No seguir las instrucciones de limpieza puede provocar lesiones o daños al equipo. Limpie el horno solo con limpiador Combitherm. El limpiador es cáustico. Evite el contacto con la piel o los ojos. Use equipos de protección personal. Lea y comprenda la hoja de datos de seguridad del limpiador Combitherm y el manual del operador antes de la limpieza.</p> </div> <div data-bbox="261 1373 630 1545" style="padding: 5px;"> <p>Respecter les instructions de nettoyage pour écarter les risques de blessures ou de dégâts matériels. Nettoyer le four uniquement avec un produit nettoyant Combitherm. Le produit nettoyant est caustique. Éviter le contact avec la peau et les yeux. Porter un EPI. Lire et comprendre la fiche de données de sécurité du produit nettoyant Combitherm et le manuel de l'utilisateur avant de nettoyer.</p> </div> <div data-bbox="570 1535 630 1556" style="font-size: x-small;"> <p>LA-22836</p> </div>	<p>Warning</p> <p>Failure to follow cleaning instructions can cause injury or equipment damage. Clean oven only with Combitherm cleaner. Cleaner is caustic. Avoid contact with skin or eyes. Wear PPE. Read and understand the Combitherm cleaner safety data sheet and the operator's manual before cleaning.</p>
<div data-bbox="120 1604 711 1864" style="border: 1px solid black; padding: 10px;"> <div style="display: flex; justify-content: space-around;"> <div style="border: 1px solid black; padding: 5px;">  </div> <div style="border: 1px solid black; padding: 5px;">  </div> <div style="border: 1px solid black; padding: 5px;">  </div> <div style="border: 1px solid blue; border-radius: 50%; padding: 5px;">  </div> <div style="border: 1px solid blue; border-radius: 50%; padding: 5px;">  </div> </div> <div style="display: flex; justify-content: space-around; margin-top: 10px;"> <div style="border: 1px solid blue; border-radius: 50%; padding: 5px;">  </div> <div style="border: 1px solid blue; border-radius: 50%; padding: 5px;">  </div> <div style="border: 1px solid blue; border-radius: 50%; padding: 5px;">  </div> <div style="border: 1px solid blue; border-radius: 50%; padding: 5px;">  </div> </div> <div data-bbox="639 1839 695 1860" style="font-size: x-small;"> <p>LA-39149</p> </div> </div>	

<div style="border: 1px solid black; padding: 5px;"> <div style="background-color: #f4a460; padding: 2px; display: flex; align-items: center;"> <b>WARNING/ADVERTENCIA/AVERTISSEMENT</b> </div> <div style="margin-top: 10px;"> <p><b>Electric Shock Hazard</b> Appliances with permanent electrical connection that are mounted on casters must be secured to building structure. Read installation instructions.</p> <p><b>Peligro de descarga eléctrica</b> Los equipos con una conexión eléctrica permanente que estén montados sobre ruedas deben estar fijos a la estructura del edificio. Lea las instrucciones de instalación.</p> <p><b>Risque d'électrocution</b> Les appareils à branchement électrique fixe qui sont montés sur roulettes doivent être attachés à la structure du bâtiment. Lire les instructions d'installation.</p> <p style="text-align: right; font-size: small;">LA-38912</p> </div> </div>	<p>Warning</p> <p>Electric Shock Hazard</p> <p>Appliances with permanent electrical connection that are mounted on casters must be secured to building structure. Read installation instructions.</p>
<div style="border: 1px solid black; padding: 5px; text-align: center;"> <p style="text-align: right; font-size: small;">LA-39148</p> </div>	
<div style="border: 1px solid black; padding: 5px;"> <div style="background-color: #f4a460; padding: 2px; display: flex; align-items: center;"> <b>WARNING/ADVERTENCIA/AVERTISSEMENT</b> </div> <div style="margin-top: 10px;"> <p><b>WARNING:</b> Improper installation, adjustment, alteration, service or maintenance can cause property damage, injury or death. Read the installation, operating and maintenance instructions thoroughly before installing or servicing the equipment.</p> <p>Water and waste connection shall comply with the basic plumbing code of the Building Officials and Code Administrators International, Inc. (BOCA) and the Food Service Sanitation Manual of the Food and Drug Administration (FDA).</p> <p><b>ADVERTENCIA:</b> Una instalación, ajuste, modificación, reparación o mantenimiento inadecuado podría producir daños en el equipo, lesiones personales e incluso la muerte. Lea las instrucciones de instalación, funcionamiento y mantenimiento detenidamente antes de instalar o reparar el equipo.</p> <p>La conexión de agua y de aguas residuales debe cumplir el Código de Tuberías Básico (Basic Plumbing Code) de Building Officials y Code Administrators International, Inc. (BOCA), y el Manual de Sanidad de Servicio de Alimentos (Food Service Sanitation Manual) de la Administración de Drogas y Alimentos (FDA, por sus siglas en inglés).</p> <p><b>AVERTISSEMENT:</b> L'installation, le réglage, la modification, la réparation ou l'entretien incorrect de cet appareil peut causer des dommages matériels, des blessures ou la mort. Lire attentivement les instructions d'installation, de fonctionnement et d'entretien avant de procéder à son installation ou entretien.</p> <p>Le raccordement d'eau et d'évacuation doit être conforme au Basic Plumbing Code de BOCA (Building Officials and Code Administrators International, Inc.) et au Food Service Sanitation Manual de la FDA (Food and Drug Administration).</p> <p style="text-align: right; font-size: small;">LA-38908</p> </div> </div>	<p>Warning</p> <p>Improper installation, adjustment, alteration, service or maintenance can cause property damage, injury or death. Read the installation, operating and maintenance instructions thoroughly before installing or servicing the equipment.</p> <p>Water and waste connection shall comply with the basic plumbing code of the Building Officials and Code Administrators International, Inc. (COCA) and the Food Service Sanitation Manual of the Food and Drug Administration (FDA).</p>

**WARNING/ADVERTENCIA/AVERTISSEMENT**

**Fire Hazard**  
For use only on noncombustible surfaces.  
Maintain the correct clearances to combustibles.

**Peligro de incendio**  
Solo para uso en superficies no combustibles.  
Mantenga las distancias correctas de elementos combustibles.

**Risque d'incendie**  
Utilisation sur des surfaces non combustibles seulement.  
Maintenir des dégagements corrects par rapport aux matières combustibles.

	Combustibles	Non-combustibles
Top/tope/haut	20" (508mm)	20" (508mm)
Left/izquierda/gauche	0" (0mm)	0" (0mm)
Right/derecho/droite	2" (51mm)	0" (0mm)
Rear/posterior/arrière	4" (102mm)	4" (102mm)

LA-38906

Warning

Fire Hazard

For use only on noncombustible surfaces. Maintain the correct clearances to combustibles.

Read the installation instructions.

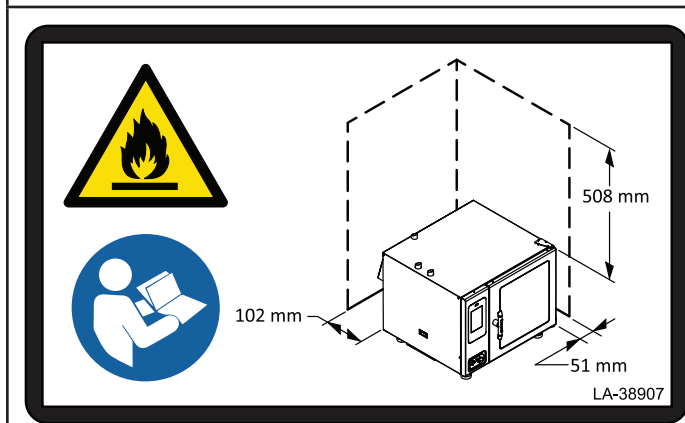

COA #5760

LA-39312

City of New York Fire Department condition of acceptance number.

**NOTICE/AVISO/AVIS**

For trained personnel only: The installation manual and the wiring diagram for this appliance can be found inside the oven attached to the opposite side of this panel.

Solo para personal capacitado: El manual de instalación y el diagrama de cableado de este equipo se pueden encontrar dentro del horno, en el lado opuesto de este panel.

Personnel formé seulement : Le manuel d'installation et le schéma de câblage de cet appareil se trouvent à l'intérieur du four attachés de l'autre côté de ce panneau.

LA-38941

Notice

For trained personnel only: The installation manual and the wiring diagram for this appliance can be found inside the oven attached to the opposite side of this panel.

<div style="border: 1px solid black; padding: 5px;">  <p><b>⚠ WARNING/ADVERTENCIA/AVERTISSEMENT</b></p> <p><b>Electric Shock Hazard</b> To reduce the risk of electric shock, do not remove or open cover. No user-serviceable parts inside. Refer servicing to qualified personnel. Qualified personnel: Disconnect power before servicing.</p> <p><b>Peligro de descarga eléctrica</b> Para reducir el riesgo de descarga eléctrica, no retire ni abra la cubierta. No hay piezas en el interior a la que se les pueda realizar mantenimiento. Derive el mantenimiento a personal calificado. Personal calificado: Desconecte la energía antes de realizar mantenimiento.</p> <p><b>Danger de décharge électrique</b> Pour réduire le risque de décharge électrique, ne par ouvrir ni retirer le capot. Ne contient pas de pièces réparables par l'utilisateur. Confier les réparations à du personnel qualifié. Personnel qualifié : Sectionnez l'alimentation avant toute intervention.</p> <p style="text-align: right;">LA-38950</p> </div>	<p>Warning</p> <p>Electric shock hazard.</p> <p>To reduce the risk of electric shock, do not remove or open cover. No user-serviceable parts inside. Refer servicing to qualified personnel.</p> <p>Qualified personnel: Disconnect power before servicing.</p>
<div style="border: 1px solid black; padding: 5px;"> <p>Use _____AWG for supply connections. Use only copper wires suitable for temperatures <math>\geq 90^{\circ}\text{C}</math>. Do not connect to a circuit operating at more than 150 VAC to ground. For use on individual branch circuits only.</p> <div style="display: flex; align-items: center; justify-content: center;"> <div style="border: 1px solid black; width: 30px; height: 30px; margin-right: 5px;"></div> <p><b>AWG 90°C</b></p> </div> <p>Use AWG _____ para las conexiones de suministro. Use solo cables de cobre aptos para temperaturas mayores que <math>90^{\circ}\text{C}</math>. No conecte a un circuito que funcione a más de 150 V CA a tierra. Para su uso en circuitos derivados individuales solamente.</p> <p>Utiliser du calibre _____AWG pour les raccordements électriques. Utiliser exclusivement des conducteurs en cuivre qui conviennent à des températures <math>\geq 90^{\circ}\text{C}</math>. Ne pas raccorder à un circuit fonctionnant sous plus de 150 VCA par rapport à la terre. Utiliser exclusivement sur des circuits de dérivation propres.</p> <p style="text-align: right;">LA-38852</p> </div>	<p>Use _____AWG for supply connections. Use only copper wires suitable for temperatures <math>\geq 90^{\circ}\text{C}</math>. Do not connect to a circuit operating at more than 150 VAC to ground. For use on individual branch circuits only.</p>
<div style="background-color: #ffff00; padding: 5px;"> <p><b>NOTICE:</b> Use only factory-supplied casters when needed. When this appliance includes casters, the following must also be installed:</p> <ul style="list-style-type: none"> <li>• a connector complying with ANSI Z21.69 / CSA 6.16;</li> <li>• a quick-disconnect device complying with ANSI Z21.41 / CSA 6.9;</li> <li>• a restraining device to guard against transmission of strain to the connector as specified in the manual.</li> </ul> <p><b>AVISO:</b> Solo use ruedas proporcionadas de fábrica cuando sea necesario. Si este equipo incluye ruedas, también se debe instalar lo siguiente:</p> <ul style="list-style-type: none"> <li>• un conector que cumpla con las normas ANSI Z21.69 y CSA 6.16;</li> <li>• un dispositivo de desconexión rápida que cumpla con las normas ANSI Z21.41 y CSA 6.9;</li> <li>• un dispositivo de sujeción para proteger contra la transmisión de tensión al conector como se especifica en el manual.</li> </ul> <p><b>AVIS :</b> S'il y a lieu, utiliser uniquement les roulettes fournies par le fabricant. Si cet appareil comporte des roulettes, les articles suivants doivent également être installés :</p> <ul style="list-style-type: none"> <li>• un connecteur conforme à ANSI Z21.69 / CSA 6.16;</li> <li>• un raccord découpleur rapide conforme à ANSI Z21.41 / CSA 6.9;</li> <li>• un moyen de retenue pour empêcher la transmission de la contrainte au connecteur comme indiqué dans le manuel.</li> </ul> <p style="text-align: right;">LA-25784</p> </div>	<p><b>NOTICE:</b> Use only factory-supplied casters when needed. When this appliance includes casters, the following must also be installed:</p> <ul style="list-style-type: none"> <li>• a connector complying with ANSI Z21.69 / CSA 6.16;</li> <li>• a quick-disconnect device complying with ANSI Z21.41 / CSA 6.9;</li> <li>• a restraining device to guard against transmission of strain to the connector as specified in the manual.</li> </ul>

## SITE INSTALLATION

 **WARNING**

Improper installation, alteration, adjustment, service, cleaning, or maintenance could result in property damage, severe injury, or death.

Read and understand the installation, operating and maintenance instructions thoroughly before installing, servicing, or operating this equipment.

**INSTALLATION CODES & STANDARDS**

The following codes and standards are required for installation of this oven:

**AIR SUPPLY, ELECTRICAL CONNECTIONS, WATER CONNECTIONS, AND WASTE WATER DISCHARGE.**

Gas oven installations shall comply with local codes required for gas appliances. In the absence of local codes, installation shall comply with the latest edition of:

- USA: National Fuel Gas Code, ANSI Z223.1 (NFPA 54). And OSHA Regulations
- Canada: Natural Gas and Propane Installation Code, CAN/CSA-B149.1-15
- EU: European Standard EN203
- Australia/New Zealand: AS 5601

Adherence to code by a qualified installer is essential for the following: gas plumbing, gas appliance installation, commercial cooking ventilation, water and plumbing.

 **WARNING**

Electric shock hazard.

Perform lockout/tagout procedures before cleaning or servicing this appliance.

**VENTILATION REQUIREMENTS**

A steam ventilation hood is mandatory for the operation of the oven. In addition, a single gas Combitherm oven requires a minimum of 28 CFM (793 LPM) make-up air for both natural and propane gas. Authorities having jurisdiction should be consulted as to the requirements for this equipment with respect to ventilation and fire extinguishing systems to ensure conformity with any Federal, State, or local installation codes.

*See the section titled Gas Exhaust*

**SOUND PRESSURE MEASUREMENTS**

The A-weighted sound pressure level without ventless hood operating is less than 70dBA.

**INSTALLATION TEMPERATURE REQUIREMENTS**

Malfunctions may occur if the oven is put into service too soon after having been stored or transported in cold temperatures. Therefore, allow the oven to acclimate to room temperature at the installation site for at least 24 hours before use. If this is impractical, install the oven as directed and immediately run it in convection mode at 450°F (232°C) for 25–30 minutes. Then proceed with completing all remaining functional tests.

**NOTICE:** ALWAYS remove the electronic control boards BEFORE welding any stainless steel components on this appliance. Failure to do so will damage the control boards and may void the warranty.

## GENERAL SPECIFICATIONS

Installation must be performed by a qualified technician. Strict adherence to local codes and standards is required for installation of this oven. Code requirements apply, but are not limited, to:

- **Air supply**
- **Electrical connections**
- **Water connections**
- **Waste water discharge**
- **Natural gas / LP supply (gaseous ovens only)**

## Water Requirements and Standards



### Water requirements (per oven)

- Two cold water inlets - drinking quality
- One treated water inlet: 3/4" NPT connection. Line pressure 30 psi minimum dynamic and 90 psi maximum static (200-600 kPa) at a minimum flow rate of 0.26 gpm (1 L/min).
- One untreated water inlet: 3/4" NPT connection. Line pressure 30 psi minimum dynamic and 90 psi maximum static (200-600 kPa) at a minimum flow rate of 2.64 gpm (10 L/min).
- Water drain: 1-1/2" (40mm) connection with a vertical vent to extend above the exhaust vent. Materials must withstand temperatures up to 200°F (93°C).



### Clearance requirements for water filtration system

Do not install a water filtration system behind unit.















### Water Quality Standards

It is the sole responsibility of the owner/operator/purchaser of this equipment to verify that the incoming water supply is comprehensively tested and, if required, a means of "water treatment" provided that would meet compliance requirements with the published water quality standards shown below. Non-compliance with these minimum standards will potentially damage this equipment and/or components and void the original equipment manufacturer's warranty. Alto-Shaam recommends using the Alto-Shaam Reverse Osmosis System to properly treat your water.





















Inlet Water Requirements		
Contaminant	Treated Water	Untreated Water
Free Chlorine	Less than 0.1 ppm (mg/L)	Less than 0.1 ppm (mg/L)
Hardness	30-70 ppm	30-70 ppm
Chloride	Less than 30 ppm (mg/L)	Less than 30 ppm (mg/L)
pH	7.0 to 8.5	7.0 to 8.5
Silica	Less than 12 ppm (mg/L)	Less than 12 ppm (mg/L)
Total Dissolved Solids (tds)	50-125 ppm	50-360 ppm

**OVEN SPECIFICATIONS**















Specification sheets for Combitherm ovens are available at [www.alto-shaam.com](http://www.alto-shaam.com). You can also view and download PDFs by scanning the QR codes on this and the following pages with the camera on your mobile device or tablet.

<b>CTC6-10E</b>	<b>CTC6-10G</b>	<b>CTC6-10E with Ventech Hood</b>	<b>Stacked CTC6-10E with Ventech Hood</b>
			
<b>Stacked CTC6-10E over CTC10-10E w/Ventech Hood</b>	<b>CTC6-10E over Vector F</b>	<b>CTP6-10E</b>	<b>CTP6-10G</b>
			
<b>CTP6-10E with Ventech Hood</b>	<b>Stacked CTP6-10E</b>	<b>Stacked CTP6-10E with Ventech Hood</b>	<b>Stacked CTP6-10E over CTP10-10E</b>
			
<b>Stacked CTP6-10E over CTP10-10E w/Ventech Hood</b>	<b>CTP6-10E over Vector F</b>	<b>Stacked CTP6-10G</b>	
			

## OVEN SPECIFICATIONS (Continued)

<b>CTC7-20E</b>	<b>CTC7-20G</b>	<b>CTC7-20E with Ventech Hood</b>	<b>Stacked CTC7-20E</b>
			
<b>Stacked CTC7-20E with Ventech Hood</b>	<b>Stacked CTC7-20G</b>	<b>CTC7-20E over Vector F</b>	<b>CTP7-20E</b>
			
<b>CTP7-20G</b>	<b>Stacked CTP7-20G</b>	<b>CTP7-20E with Ventech Hood</b>	<b>Stacked CTP7-20E</b>
			
<b>Stacked CTC7-20E with Ventech Hood</b>	<b>CTP7-20E over Vector F</b>	<b>CTC10-10E</b>	<b>CTC10-10G</b>
			
<b>CTC10-10E with Ventech Hood</b>	<b>CTP10-10E</b>	<b>CTP10-10GE</b>	<b>CTP10-10E with Ventech Hood</b>
			

OVEN SPECIFICATIONS (Continued)

Stacked CTP10-10E over CTP7-20E	CTC10-20E	CTC10-20G	CTC10-20E with Ventech
			
CTP10-20E	CTP10-20G	CTP10-20E with Ventech Hood	CTC20-10E
			
CTC20-10G	CTP20-10E	CTP20-10G	CTC20-20E
			
CTC20-20G	CTP20-20E	CTP20-20G	
			

## SITE INSTALLATION

### **WARNING**

To prevent serious injury, death, or property damage:

- **Always** keep appliance on top of a pallet when using a fork lift or a pallet lift truck to move appliance.
- **Always** use a sufficient number of trained and experienced workers to place the appliance on floor, stand, or counter.

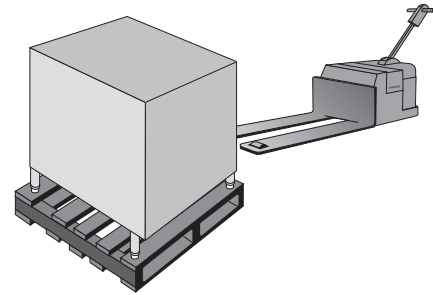
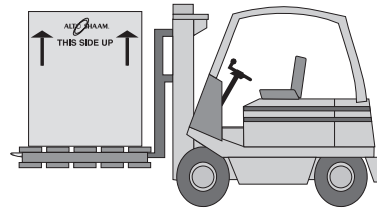

## INSTALLATION

To ensure proper operation, the installation of this oven must be completed by qualified technicians in accordance with the instructions provided in this manual. Failure to follow the instructions provided may result in damage to the oven, building, or cause personal injury to personnel.

**NOTICE:** To prevent PROPERTY DAMAGE: Check the dimensions of the doorways and aisles before attempting to move the oven and pallet to the installation site.

Do not tilt the oven. Transport the oven in an upright and level position only.

Slide the preheat strip into place before using a forklift or pallet jack in between the trolley guides to avoid damaging the preheat strip when lifting.

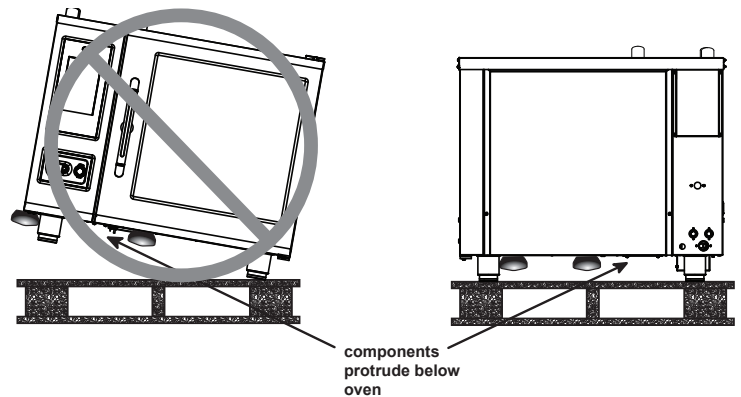

## LIFTING INSTRUCTIONS

Remove banding before lifting. **Lift the unit from the front only, never from the side.**

Adjust the forks so that they do not damage any of the components under the unit. **Note that the control side of the oven is the heaviest portion.** Lift the unit just high enough to remove the wooden pallet. Lower the unit as close to the floor as possible and no more than 2" (50mm) above the floor. Secure hoses and dangling cords to avoid tangling or damage. **When moving the unit, drive slowly, keep it low to the ground, and use extreme caution.**

**DEPTH OF FORKS IS CRITICAL FOR UNITS EQUIPPED WITH GREASE COLLECTION TO AVOID DAMAGING THE PUMP**

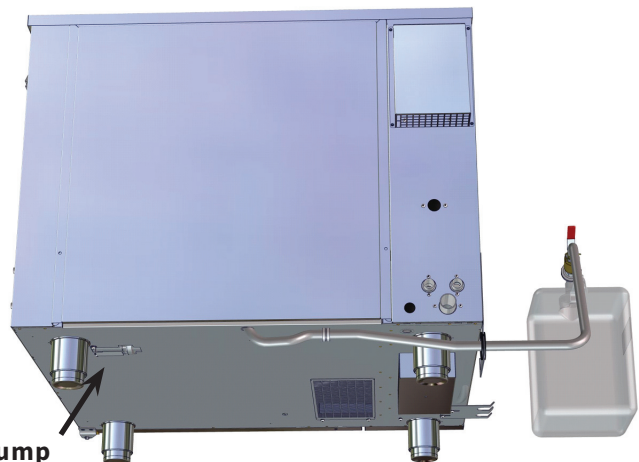

**SITE INSTALLATION**

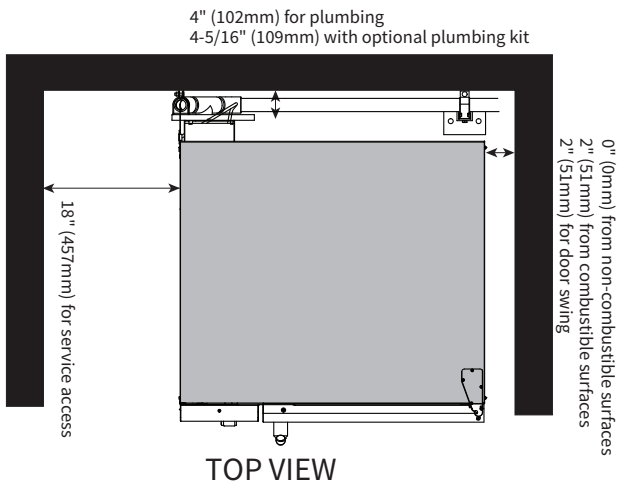

MINIMUM CLEARANCE REQUIREMENTS	
<b>LEFT SIDE</b>	0" (0mm) <b>MINIMUM</b> 18" (457mm) <b>RECOMMENDED SERVICE ACCESS</b>
<b>RIGHT SIDE</b>	0" (0mm) FROM NON-COMBUSTIBLE SURFACES 2" (51mm) FROM COMBUSTIBLE SURFACES 2" (51mm) FOR DOOR SWING
<b>BACK</b>	4" (102mm) <b>FOR PLUMBING</b> 4-5/16" (109mm) <b>FOR OPTIONAL PLUMBING KIT</b>
<b>TOP</b>	20" (508mm) <b>FOR AIR MOVEMENT</b>
<b>BOTTOM</b>	5-1/8" (457mm) <b>FOR LEGS AND UNOBSTRUCTED AIR INTAKE</b>

**NOTICE:** • A minimum distance of 18" (457mm) is strongly recommended for service access. If adequate service clearance is not provided, it will be necessary to disconnect the gas, water, and drain to move the oven with a forklift for service access. Service charges in connection with inadequate service access are not covered under warranty.

- Do not install a stacked combination directly over a drain. Steam rising up out of the drain will adversely affect operation, hamper cooling air circulation, and may damage electrical and electronic components. Failure to comply will void the warranty. A single oven installed on a stand with solid surface bottom shelf can be positioned over a drain since the solid surface will block the rising steam.

**POSITIONING ON SITE - COUNTERTOP MODELS**

Place the oven on a stable, non-combustible level horizontal surface. Use the adjustable feet to level the unit if the floor is uneven.

It is strongly recommended that tabletop models be mounted on a factory supplied stand or a stand that is stable, open, and level. The adjustable oven legs should be extended beyond the depth of the positioning ring to allow for leveling after the oven has been placed on the stand.

Each of the legs on the stand and the oven can be adjusted 2" (51mm) up or down.

Level the oven from front-to-back and side-to-side by means of the adjustable legs. Components within the oven condenser tank are sensitive to pitch and can be damaged. The tolerance to level is +/- 0.125" (3.2mm). If this tolerance range is not achievable, the floor must be repaired to obtain level.

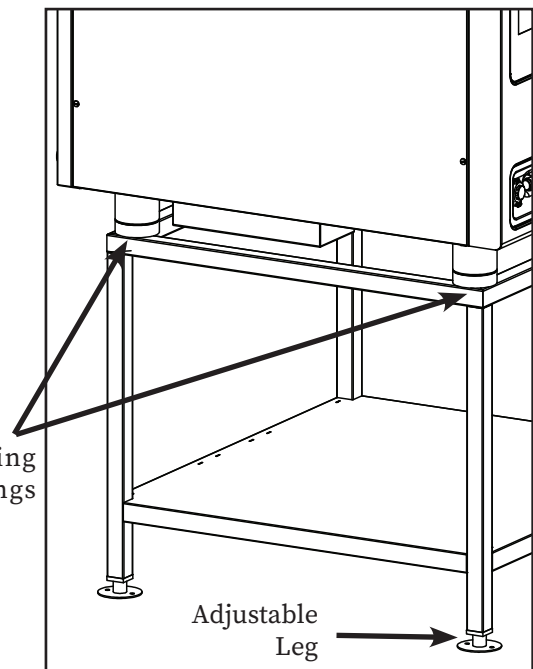
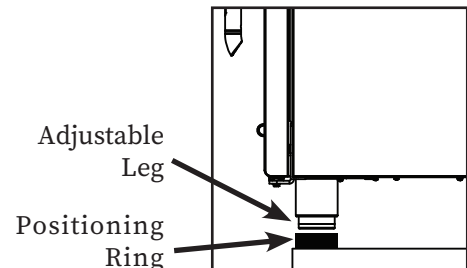
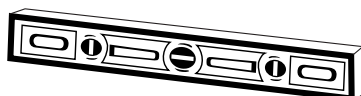
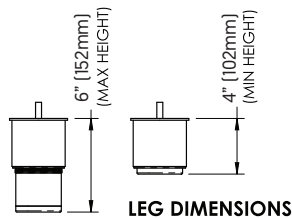

## SITE INSTALLATION

### POSITIONING ON SITE — 20-10 & 20-20 MODELS

Place the oven on a stable, non-combustible level horizontal surface. Use the adjustable feet to level the unit if the floor is uneven.

- Once the unit has been positioned properly beneath a ventilation hood system, adjust the four outside feet located on the outside corners of the base frame. Begin with a 32mm (1.25") height (illustration 1) leveling the oven from side-to-side and front-to-back (illustration 2).

## NOTICE

To ensure proper fit of the trolley, the overall height of the oven must meet this specification:

Minimum: 79-7/8" (203 cm)

Maximum: 80-3/8" (204 cm)

In addition, the vertical distance from the bottom of the door frame to the floor must meet this specification:

Minimum: 8-1/4" (210mm)

Maximum: 8-3/4" (222mm)

- Roll the trolley into the oven and check the overall fit of the trolley. Close the door and check fit. Make adjustments as needed.

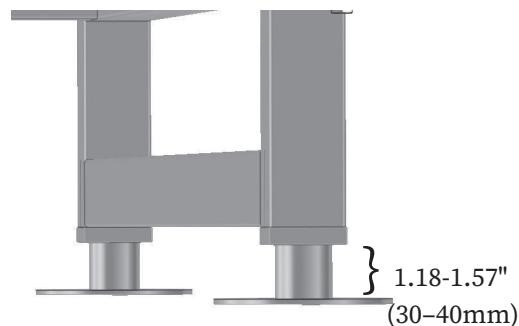
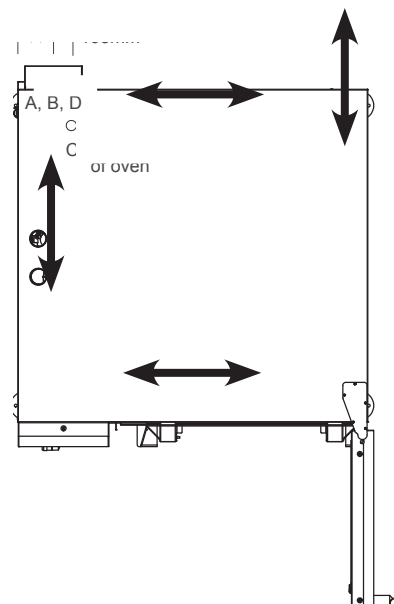

Illustration 1

Illustration 2



**NOTICE:** Adjustable measurements are from the top of the leg flange to the bottom of the leg square frame (see illustration 1). If measurements exceed 1.57" (40mm) in height or trolley is not on a level and stable horizontal floor, the following may occur:

- Improper sealing of the door sweep gasket to the trolley plate, or heat strip.
- Trolley may not fit properly.

## SITE INSTALLATION

 **CAUTION**

Power source must match voltage identified on appliance rating tag. The rating tag provides essential technical information required for any appliance installation, maintenance or repairs. Do not remove, damage or modify the rating tag.

 **WARNING**

To prevent serious injury, death, or property damage:

All electrical connections must be made by a qualified and trained service technician in accordance with applicable electrical codes.



This appliance must be adequately grounded in accordance with local electrical codes or, in the absence of local codes, with the current edition of the National Electrical Code ANSI/NFPA No. 70. In Canada, all electrical connections are to be made in accordance with CSA C22.1, Canadian Electrical Code Part 1 or local codes.



CE-approved appliances include an equipotential-bonding terminal marked with the symbol shown on the left. Provisions for earthing are to be made in accordance with IEC:2010 60335-1 section 27 or local codes.

 **WARNING**

Appliances without a cord provided by the factory must be equipped with a cord of sufficient length to permit the appliance to be moved for cleaning.

Always use the correct AWG wire size based on the electrical requirements for the appliance.

 **WARNING**

Improper installation, alteration, adjustment, service, cleaning, or maintenance could result in property damage, severe injury, or death.

Read and understand the installation, operating and maintenance instructions thoroughly before installing, servicing, or operating this equipment.

 **WARNING**

Electric shock hazard.

Perform lockout/tagout procedures before cleaning or servicing this appliance.

## ELECTRICAL CONNECTION FOR GAS MODELS

- 1. An electrical wiring diagram is located behind the control panel on the left side of the oven.** This appliance must be branch circuit protected with proper ampacities, in accordance with the wiring diagram.
- For 1-phase applications, the ground fault or residual current protection device must accommodate a leakage current of 20 mA.
- Wire size for the main incoming power to the unit must match the minimum size listed in the specifications applicable to the specific oven model. For supply connections, locate the wire size posted on the label located on the electrical control box cover behind the service panel.
- Before operating the oven, check all cable connections and electrical terminal connections in the electrical connection area for tightness. Connections can loosen during transport.

**NOTICE:** Check motor rotation on the Combitherm® CT Classic CTC model line. Arrows on the motor housing indicate proper rotation.

- After both water and electrical connections have been completed on all Combitherm model types, operate the oven in any cooking mode for a period of 15 minutes.
- Recheck the main power connections at the terminal block, cable connections, and electrical terminal connections to make certain they remain tight.

## ELECTRICAL CONNECTION FOR ELECTRIC MODELS

**NOTICE:** All models must be equipped with a country certified external allpole disconnection switch with sufficient contact separation.

An oil resistant cord like H05RN or H07RN or equivalent must be used.

- 1. An electrical wiring diagram is located behind the control panel on the left side of the oven.** This appliance must be branch circuit protected with proper ampacities, in accordance with the wiring diagram.
- Wire size for the main incoming power to the unit must match the minimum size listed in the specifications applicable to the specific oven model. For supply connections, locate the wire size posted on the label located on the electrical control box cover behind the service panel.
- Before operating the oven, check all cable connections and electrical terminal connections in the electrical connection area for tightness. Connections can loosen during transport.

**NOTICE:** Check motor rotation on the Combitherm® CT Classic CTC model line. Arrows on the motor housing indicate proper rotation.

- After both water and electrical connections have been completed on all Combitherm model types, operate the oven in any cooking mode for a period of 15 minutes.
- Recheck the main power connections at the terminal block, cable connections, and electrical terminal connections to make certain they remain tight.

ELECTRICAL KIT INSTALLATION – 50 Hz (Rear Panel with Cover Plates)

International Applications

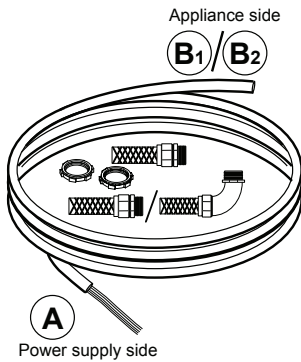

**1**

**A**

Cut threads into nut before installing fitting. To do so, apply a light lubricant and thread nut on and off fitting.

**B<sub>2</sub>**

\* For 1-phase appliances remove red wire and orange wire.

**B<sub>1</sub>**

\* For 1-phase appliances remove red wire and orange wire.

**3** Discard the cover plate if applicable. Position and attach the support plate (x).

**2** Remove enough cable covering so that wires reach the terminal strip. Depending on the application, install the straight or elbow fitting to the cable.

**4** Install the fitting/wiring to the appliance. 1-1/2" NPT and smaller bushings through the bottom, all others through the back.

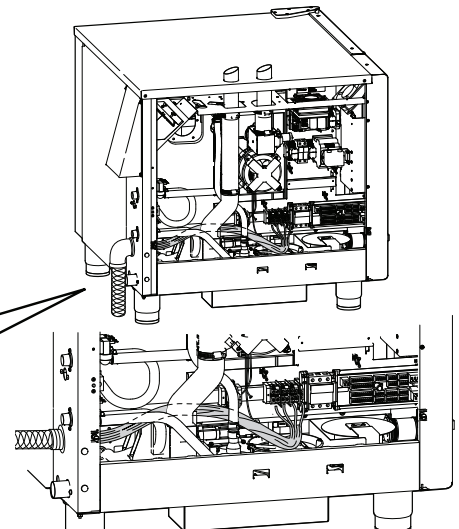
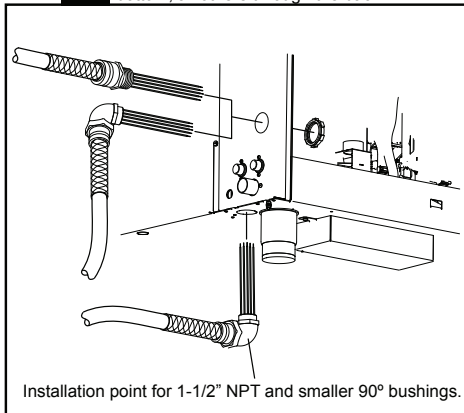

**5** Route the wires. Keep wires away from hot surfaces such as: water tank, drain pipe, motor, edges of sheet metal, vent pipes, or other appliances.

**6** Strip the wires, then connect them to the terminal strip. Note: Illustrations are representative only. Your appliance may vary.

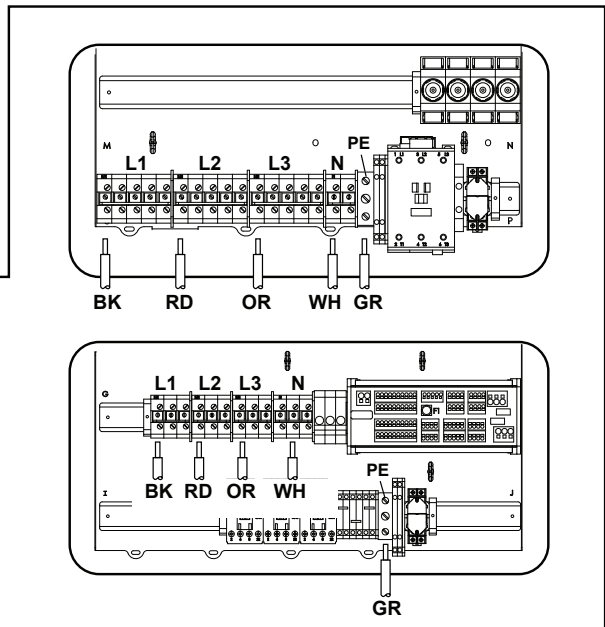
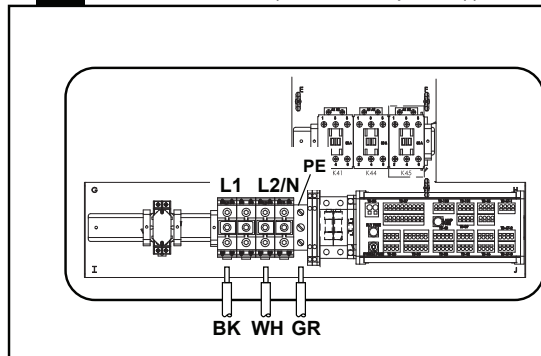

## ELECTRICAL KIT INSTALLATION - 50 Hz

### International Applications

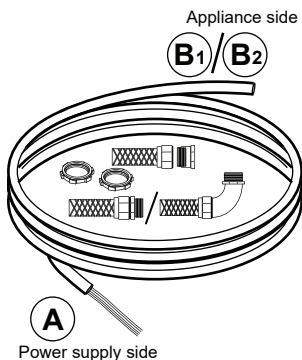

**1**

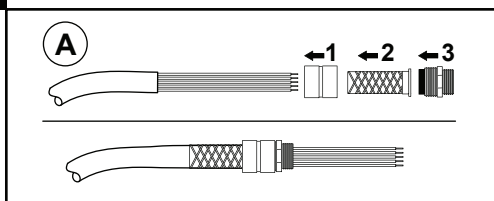

**2**

Remove enough cable covering so that wires reach the terminal blocks. Depending on the application, install the straight or the elbow fitting on to the cable.

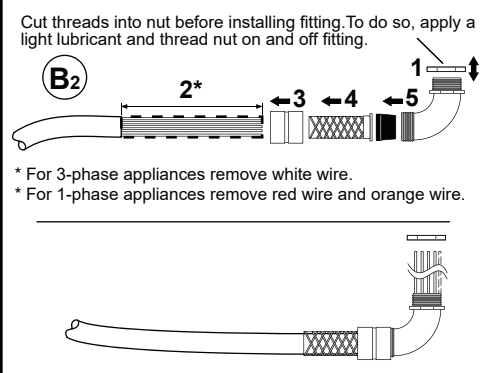
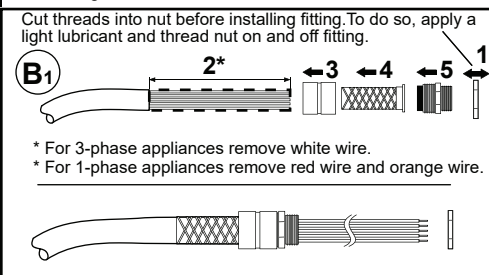

**5**

Strip the wires, then connect them to the terminal blocks.  
Note: Illustrations are representative only. Your oven may vary.

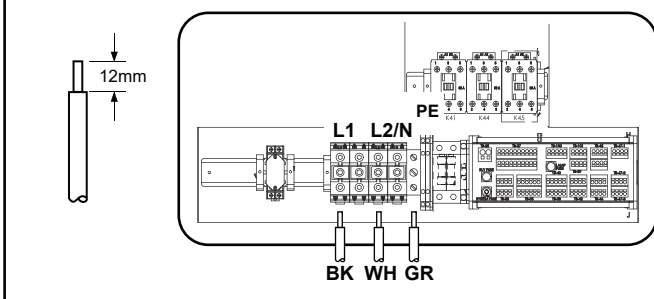

**3**

Install the fitting/wiring to the oven. Match the cable bushing to the correct sized knockout, remove the knockout.

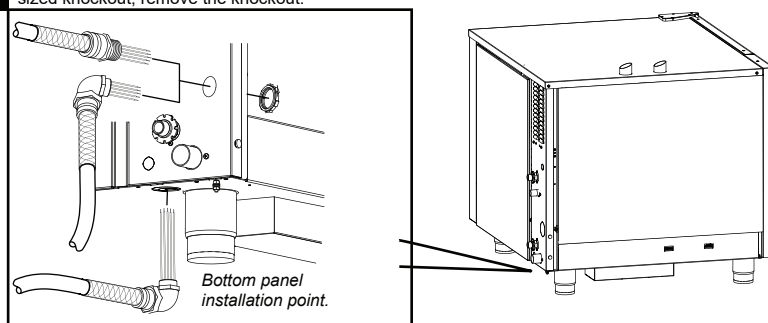

**4**

Route the wires. Keep wires away from hot surfaces such as water tank, drain pipe, motor, edges of sheet metal, vent pipes, or other appliances.

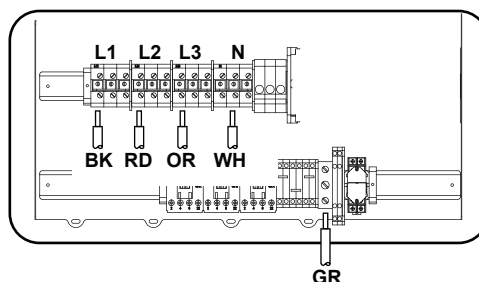
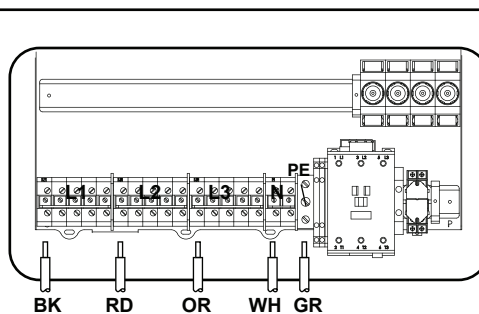
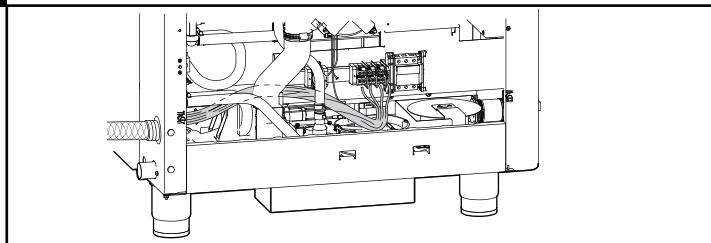

ELECTRICAL KIT INSTALLATION – 60 Hz (Rear Panel with Cover Plates)

Applications for the Americas

Note: Cabling and connectors must be supplied for 120V configurations.

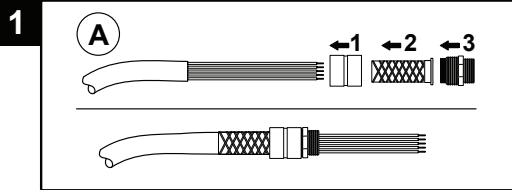
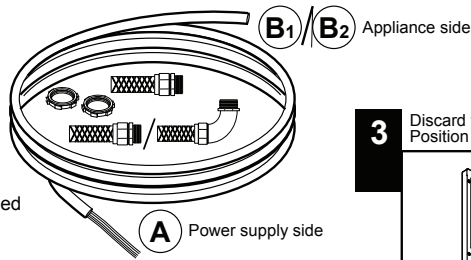

**2** Remove enough cable covering so that wires reach the terminal strip. Depending on the application, install the straight or elbow fitting to the cable.

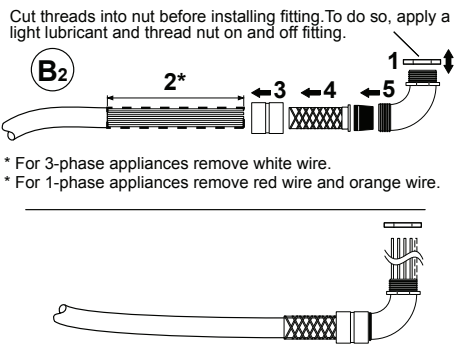
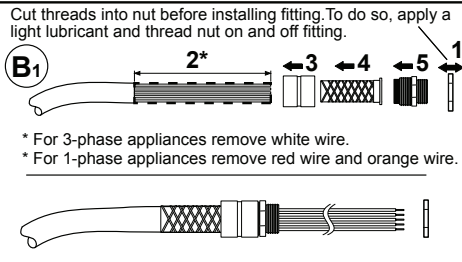

**3** Discard the cover plate if applicable. Position and attach the support plate (x).

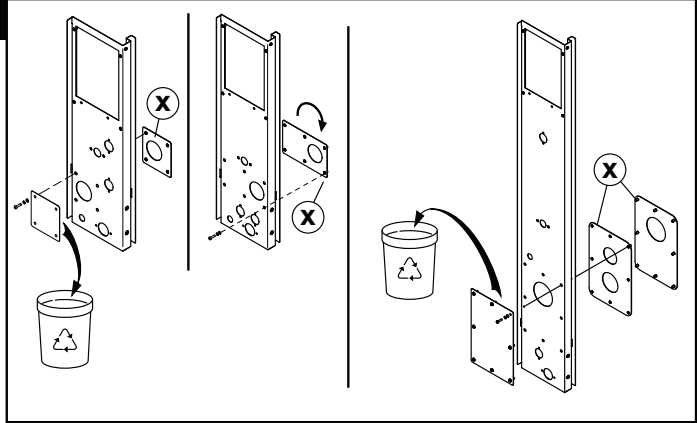

**4** Install the fitting/wiring to the appliance. 1-1/2" NPT and smaller bushings through the bottom, all others through the back.

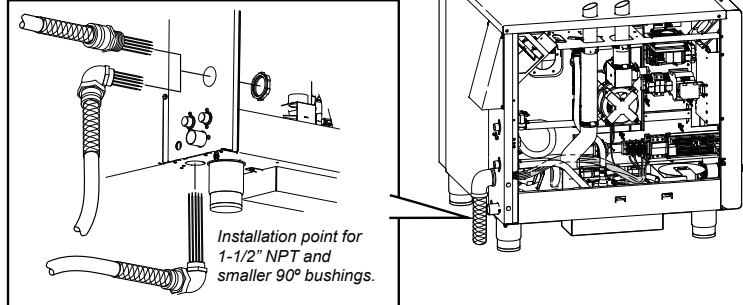

**5** Route the wires. Keep wires away from hot surfaces such as water tank, drain pipe, motor, edges of sheet metal, vent pipes, or other appliances.

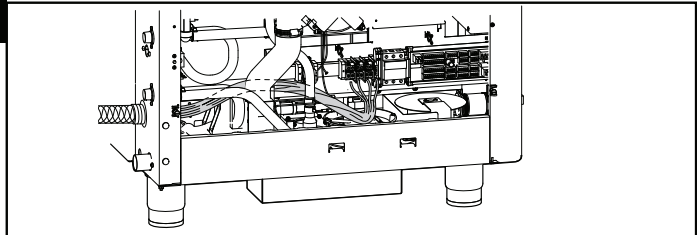

**6** Strip the wires, then connect them to the terminal strip. Note: Illustrations are representative only. Your appliance may vary.

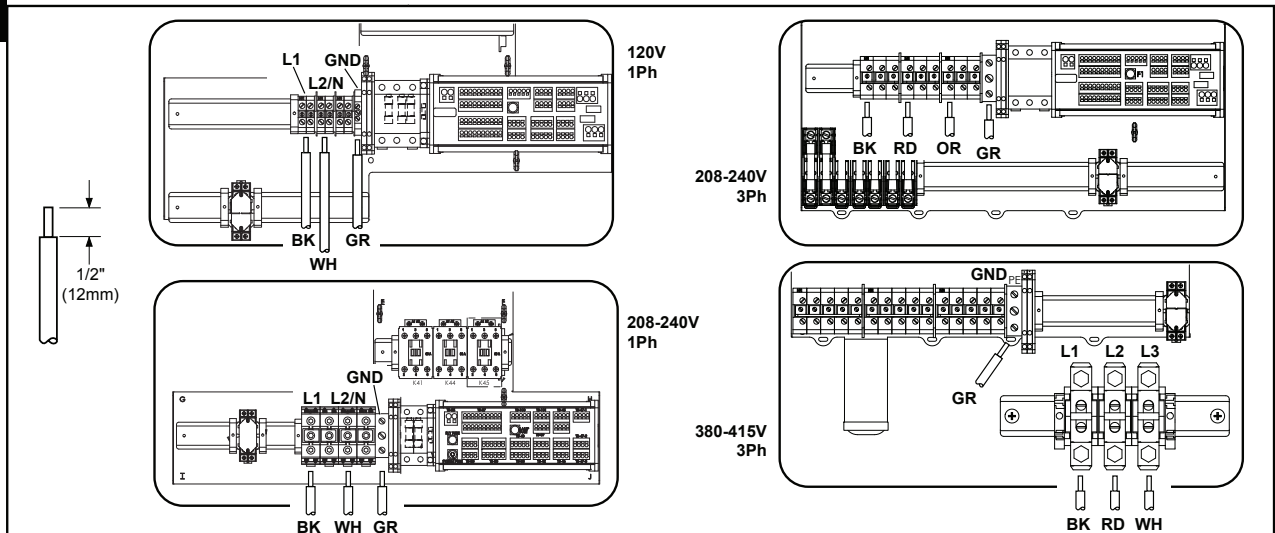

# Installation

## ELECTRICAL KIT INSTALLATION - 60 Hz

### Applications for the Americas

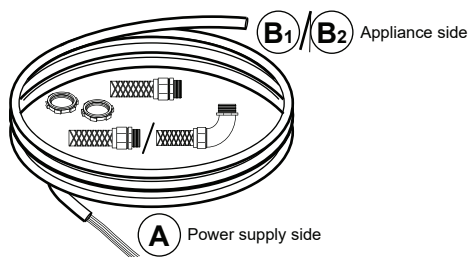

**Note:** Cabling and connectors must be supplied for 120V configurations.

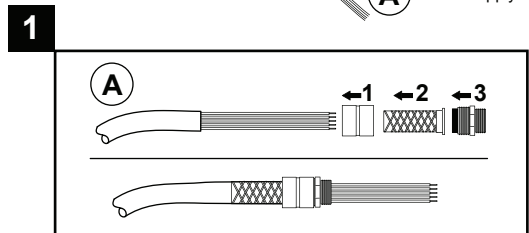

Remove enough cable covering so that wires reach the terminal blocks. Depending on the application, install the straight or the elbow fitting on to the cable.

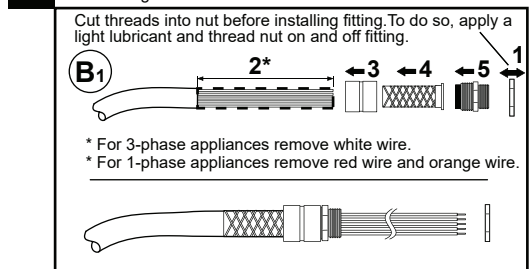

Cut threads into nut before installing fitting. To do so, apply a light lubricant and thread nut on and off fitting.

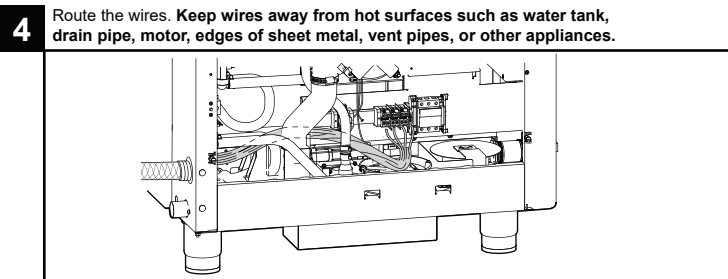
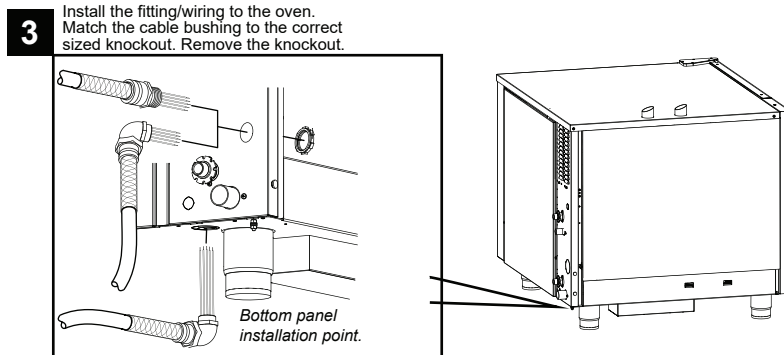
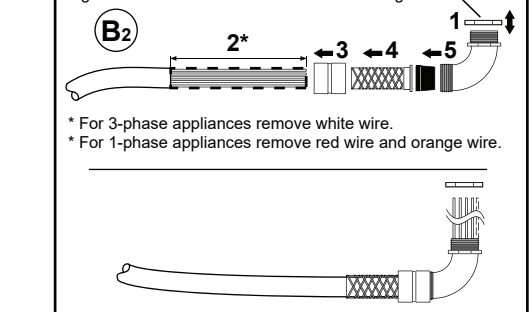

**5** Strip the wires, then connect them to the terminal blocks. Note: Illustrations are representative only. Your oven may vary.

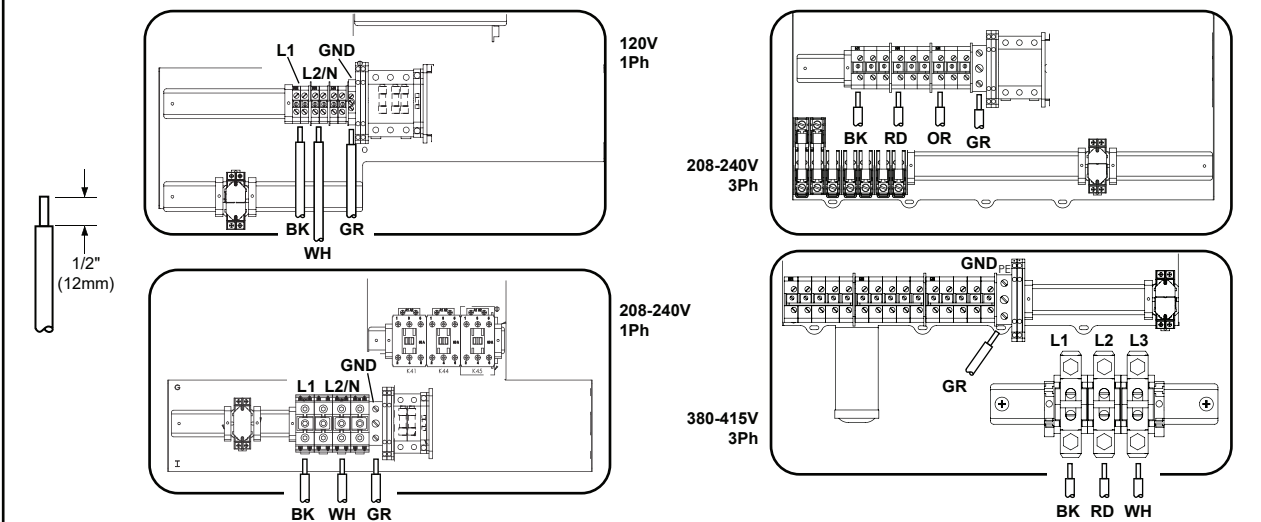

## VENTILATION REQUIREMENTS FOR GAS MODELS

**WARNING**

To prevent **SERIOUS INJURY, DEATH, or PROPERTY DAMAGE:**

Installation, air adjustment and/or service work must be in accordance with all local codes and must be performed by a trained service technician qualified to work on gas appliances.

1. A single gas Combitherm oven requires a minimum of 28 CFM (793 LPM) make-up air for both natural and propane gas. The bottom of the oven allows necessary air flow into the appliance necessary for gas combustion and must be kept clear at all times.



**DO NOT** obstruct or restrict ventilation nor the air flow required to support combustion.

2. It is especially critical that gas supply piping and electrical support cord and/or receptacle be routed away from the path of the hot combustion fumes.
3. Make certain the oven installation maintains adequate air ventilation to provide cooling for electrical and gas components. The area around the oven should be clear of any obstructions which might impede the flow of cooling air. Failure to provide sufficient air ventilation may result in damage to the components and will void the warranty.
4. This oven cannot be direct vented.
5. Install the oven under a ventilation hood meeting all applicable code requirements. Combustion fumes must be vented in accordance with local, state, or national codes.

**NOTICE**

Inadequate ventilation, or failure to ensure an adequate air flow may result in high ambient temperatures at the rear of the appliance. High ambient temperatures can cause the thermal-overload protection device on the blower motor to trip resulting in severe damage to the blower motor.

An adequate ventilation system is required for commercial cooking equipment. The minimum ventilation system shall comply with local regulations and relevant codes. In the absence of local codes, the ventilation system shall comply with:

- USA and Canada: NFPA 96
- EU: EN203
- Australia/New Zealand: AS 1668.1 and AS 1668.2

The oven must be installed under a ventilation hood listed to ANSI/UL 705 (latest edition).

**WARNING**

**DO NOT** obstruct or block exhaust flues or attach any flue extension that may impede proper burner operation, restrict the exhaust fumes and cause negative backdraft or the appliance to shut down. Failure to do so may result in serious injury or death.

**WARNING**

Failure to properly vent this appliance may cause **SERIOUS INJURY, DEATH, or PROPERTY DAMAGE**. The formation of volatile substances may cause suffocation, equipment damage, operational problems and unsatisfactory cooking performance as a consequence of improper venting and is not covered by your warranty.

Ventilation hoods and exhaust systems shall be permitted to be used to vent appliances installed in commercial applications.

**In accordance with NFPA 54 for the Commonwealth of Massachusetts only:**

Where automatically operated appliances are vented through a ventilation hood or exhaust system equipped with a damper or with a power means of exhaust, provisions shall be made to allow the flow of gas to the main burners only when the damper is open to a position to properly vent the appliance and when the power means of exhaust is in operation.

## GAS SUPPLY AND INSTALLATION

### WARNING



To prevent SERIOUS INJURY or DEATH from fire or explosion:

Only connect the type of gas indicated on the identification nameplate. Your gas Combitherm® is equipped to operate using only the fuel type specified on the identification name plate. Should conversion from natural gas to propane or from propane to natural gas be desired, conversion parts must be ordered from Alto-Shaam. Conversions must be performed by an **Alto-Shaam authorized service provider only.**

**Always ensure the oven's nameplate reflects the intended fuel type for your oven.**

Residential gas connections and hard-piped gas connections DO NOT meet NSF certifications and should NEVER be used with your Combitherm oven.

Please refer to model specifications for rated thermal loads and connected pressure requirements.

Natural	Cat	Gas Type
GR	II <sub>2</sub> H3B/P	2H-G20-20mbar
CY	II <sub>2</sub> H3B/P	2H-G20-20mbar
ES/FR/GB/IE/CH	II <sub>2</sub> H3P	2H-G20-20mbar
AT	II <sub>2</sub> H3B/P	2H-G20-20mbar
BE	II <sub>2</sub> E(S)3B/P	2H-G20-20mbar
DE	II <sub>2</sub> ELL3B/P	2E-G20/G25-20mbar
NL	II <sub>2</sub> L3B/P	2L-G25-25mbar
Butane/Propane Mixture	Cat	Gas Type
GR	II <sub>2</sub> H3B/P	3B/P-G30/G31-30mbar
CY	II <sub>2</sub> H3B/P	3B/P-G30/G31-30mbar
ES/FR/GB/IE/CH	II <sub>2</sub> H3P	3P-G31-30mbar
AT	II <sub>2</sub> H3B/P	3B/P-G30/G31-50mbar
BE	II <sub>2</sub> E(S)3P	3P-G31-30mbar
DE	II <sub>2</sub> ELL3B/P	3B/P-G30/G31-50mbar
NL	II <sub>2</sub> L3B/P	3B/P-G30/G31-30mbar
AUS/NZ	—	NGN 1.13 kPa
AUS/NZ	—	LPG-X Propane 2.75 kPa
Japan	—	Natural Gas 13A 1.96 kPa
Japan	—	LPG - Propane 2.8 kPa

Installation shall comply with local codes required for gas appliances. In the absence of local codes, installation shall comply with the latest edition of:

- USA: National Fuel Gas Code, ANSI Z223.1 (NFPA 54). And OSHA Regulations
- Canada: Natural Gas and Propane Installation Code, CAN/CSA-B149.1-15
- EU: European Standard EN203
- Australia/New Zealand: AS 5601

**NOTICE:** Connection components not supplied by Alto-Shaam must comply with the regulations in force of the country of use.

### SEDIMENT TRAP REQUIRED:

A sediment trap shall be installed downstream of the appliance shutoff valve as close to the inlet of the appliance as practical at the time of appliance installation. The sediment trap shall be either a tee fitting with a capped nipple in the bottom outlet, as illustrated below or another device recognized as an effective sediment trap.

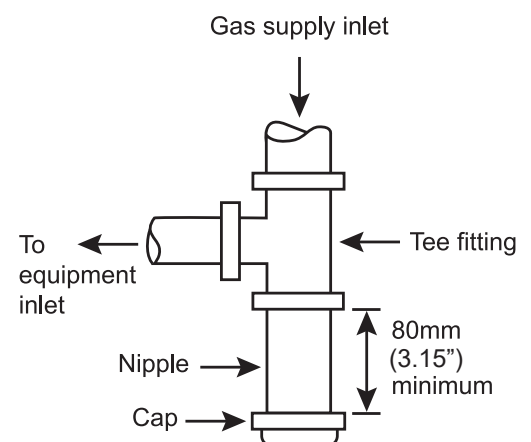

**GAS SUPPLY AND INSTALLATION**

**WARNING**



Improper installation, adjustment of burner pressures, alteration, service, maintenance, or use can cause carbon monoxide poisoning, explosion, fire, electrical shock, or other conditions which may cause **SERIOUS INJURY, DEATH or PROPERTY DAMAGE**. Consult a qualified and trained installer, service agency, local gas supplier, or your distributor for information or assistance. The qualified and trained installer or agency must use only factory-authorized and listed kits or accessories when modifying this appliance.

**INSTALLATION REQUIREMENTS**

**GAS CONNECTION: 3/4" NPT**

For Europe, gas connection thread fittings should conform to EN ISO 228-1, or ISO 7-1, or shall have a compression fitting.

If the appliance has casters, a restraint system must be installed. See section *Mobile Equipment Restraint*.

**NOTE:** If a flexible gas line is used, it must be AGA approved, commercial type and at least 3/4" I.D. or comply to European Standard EN203.

**HOOD INSTALLATION IS REQUIRED**

After installation, burner and gas valve should be checked and adjusted by a qualified and trained Alto-Shaam technician for proper operation and validate CO2 levels. **GAS VALVE MAY REQUIRE FIELD ADJUSTMENT ABOVE 2,000' (610m) AND IS NOT ADJUSTED AT THE FACTORY.**

**GAS TRAIN - ORIFICE**

When converting gas units to either propane or natural gas you will need to provide the corresponding orifice and restrictor plate, and new serial data tags, part numbers: LA-26348 and LA-26349

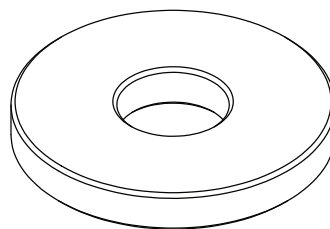

**WARNING**



Electric shock hazard.

Perform lockout/tagout procedures before cleaning or servicing this appliance.

Item	Part	Description	Qty.
1	OR-35874	ORIFICE, GAS VALVE DISC 4.60mm, 6-10 G25, 10-20 G31, 20-20 G31	1
2	OR-35876	ORIFICE, GAS VALVE DISC 2.60mm, 6-10 G30	1
3	OR-35877	ORIFICE, GAS VALVE DISC 4.00mm, 10-10 G30, 20-10 G30, 7-20 G30	1
4	OR-35878	ORIFICE, GAS VALVE DISC 4.10mm, 10-10 G31, 20-10 G31, 10-20 G30, 20-20 G30	1
5	OR-35943	ORIFICE, GAS VALVE DISC 5.70mm, 10-10 G20, 20-10 G20, 10-20 G20, 20-20 G20	1
6	OR-36006	ORIFICE, GAS VALVE DISC 6.30mm, 7-20 G25	1
7	OR-36007	ORIFICE, GAS VALVE DISC 6.00mm, 10-10 G25, 20-10 G25	1
8	OR-36207	ORIFICE, GAS VALVE DISC 6.40mm, 10-20 G25, 20-20 G25	1
9	OR-36625	ORIFICE, GAS VALVE DISC 3.75mm, 6-10 G20	1
10	OR-36626	ORIFICE, GAS VALVE DISC 2.75mm, 6-10 G31	1
11	OR-36627	ORIFICE, GAS VALVE DISC 5.55mm, 7-20 G20	1
12	OR-36628	ORIFICE, GAS VALVE DISC 4.20mm, 7-20 G31	1

NOTE: Natural Gas = G20  
 Propane = G31  
 Butane = G30  
 Low Calorific Natural Gas = G25

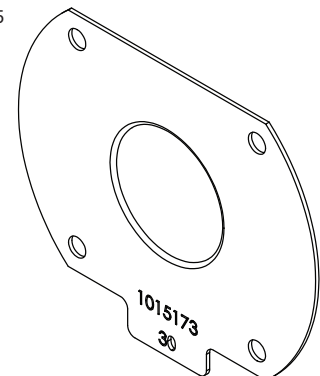

**GAS TRAIN - RESTRICTOR PLATE**

Item	Part	Description	Qty.
1	1012504	PLATE, RESTRICTOR COMBI, 20mm, 10-20 G30, 20-20 G30	1
2	1012817	PLATE, RESTRICTOR COMBI, 25mm, 7-20 G25	1
3	1013843	PLATE, RESTRICTOR COMBI, 14mm, 6-10	1
4	1013844	PLATE, RESTRICTOR COMBI, 21mm, 10-20 G25, 20-20 G25	1
5	1013845	PLATE, RESTRICTOR COMBI, 22mm, 10-20 G20, 10-20 G31, 20-20 G20, 20-20 G31	1
6	1014619	PLATE, RESTRICTOR COMBI, 17mm, 10-10 G31, 10-10 G30, 20-10 G31, 20-10 G30	1
7	1015074	PLATE, RESTRICTOR COMBI, 18mm, 10-10 G20, 10-10 G25, 20-10 G20, 20-10 G25	1
8	1015075	PLATE, RESTRICTOR COMBI, 23mm, 7-20 G31	1
9	1015076	PLATE, RESTRICTOR COMBI, 24mm, 7-20 G20, 7-20 G30	1

## GAS SUPPLY AND INSTALLATION

### WARNING



To prevent **SERIOUS INJURY, DEATH, or PROPERTY DAMAGE**:

Installation, air adjustment and/or service work must be in accordance with all local codes and must be performed by a trained service technician qualified to work on gas appliances.

**Remove any tape or compound residue on all external thread connections before proceeding.**

Use an approved gas pipe sealant at all external threaded connections, Gas piping used on gas

connections must avoid sharp bends that may restrict the flow of gas to the appliance. If the connected pressure exceeds 14.0" W.C. (3.5 kPa), a step-down regulator is required to be supplied by the owner/operator.

Close the individual manual shut-off valve to **isolate the appliance** from the gas supply piping system during any pressure testing at test pressures equal to or less than 1/2 psig (3.4 kPa). The appliance and individual shut-off valve **must be disconnected** from the gas supply piping system during any pressure testing at pressures in excess of 1/2 psig (3.4 kPa).

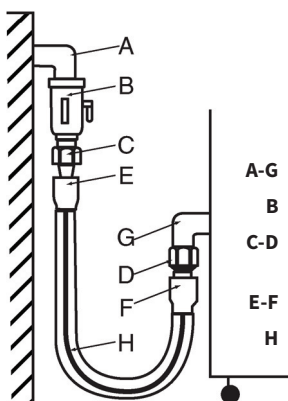
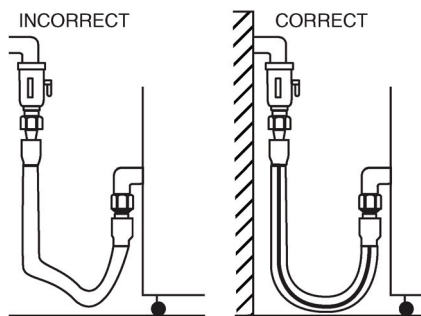

GAS INTAKE

- A-G Installation elbow
- B Ball Valve
- C-D Three-piece union fitting (minimum 1 per installation)
- E-F End connector for the flexible tube
- H Marking line



### WARNING



To prevent personal injury, death or property damage:

**Do not** store or use gasoline or other flammable vapors or liquids in the vicinity of this or any other appliance.

### WARNING



To prevent **SERIOUS INJURY, DEATH or PROPERTY DAMAGE**:

**DO NOT** spray aerosols in the vicinity of this appliance when in operation.



### CAUTION



To prevent **INJURY or PROPERTY DAMAGE**, make certain the area around the appliance is kept clear of combustible items.

In the U.S.A., installation must conform to local codes or, in the absence of local codes, with the current edition of the **National Fuel Gas Code**, NFPA-54 and ANSI Z83.11a CSA 1.8a 2004 (or latest edition). In Canada, installation must be in accordance with local codes, CAN/CGA-B149.1, **Installation for Natural Gas Burning Appliances and Equipment** (latest edition) or CAN/CGAB149.2 **Installation for Propane Burning Appliances and Equipment** (latest edition). In Europe, installation must be in accordance with European Standard EN203.

The inlet supply line must be properly sized to accommodate all individual appliances simultaneously used on the same line but must never be smaller than 3/4" NPT.

## GAS SUPPLY AND INSTALLATION

**WARNING**

To prevent SERIOUS INJURY, DEATH, or PROPERTY DAMAGE:

Always use proper length pipes to avoid stress on the gas control manifold.

Always use an approved gas pipe sealant at all external threaded connections.

Always remove any tape or compound residue on all external thread connections before installing appliance.

The minimum size requirement for gas piping or a flexible connector is 3/4 inch (19mm). For long runs of gas piping, the pipe diameter must conform to the tables in the National Fuel Gas Code, ANSI/NFPA Z223.1 or European Standard EN203.

A listed gas shut-off valve must be installed upstream of the appliance to shut off the gas supply during servicing. The shut-off valve should be accessible with the appliance in the normal installation position.

If the oven or the oven stand is supplied with casters, the gas connection must be made with a flexible connector that complies with the Standard for Connectors for Movable Gas Appliances, ANSI Z21.69; or in Canada, Connectors for Movable Gas Appliances, CAN/CGA-6.16-M87. When using a flexible connector, a quick disconnect device must be used to comply with the Standard for Quick-Disconnect Devices for Gas Fuels, ANSI Z21.41; or in Canada, Quick Disconnect Devices for Use with Gas Fuels, CAN1-6.9 or European Standard EN203. In Australia / New Zealand AS 5601, AS 1869.

When a quick disconnect device and flexible connector are used, a restraining device must be installed to limit the movement of the appliance and prevent damage to the connector or quick disconnect. An example of a restraining device is a 2000 pound (907kg) test stainless steel cable, attached to a structural member of the kitchen wall behind the oven. The means of attachment should consist of a quick connect snap so the oven can be disconnected when the appliance must be moved away from the wall.

The other end of the cable should be permanently attached to the rear frame of the oven. The cable should be of sufficient length so that no strain is ever placed on the flexible gas connector in the event of accidental movement of the oven without properly disconnecting the gas connector. The flexible connector should be routed to form a downward “U” loop between the building gas supply and the permanent attachment at the rear of the oven.

The routing of the flexible connector must not run along the side of the exhaust stacks or cross the exhaust stacks. Oven temperatures achieved during operation are too hot for safe operation. Gas piping should be installed from the point of gas connection at the back of the oven and run away from the exhaust stacks where the flexible connector may be safely used. See the illustration for the area to avoid.

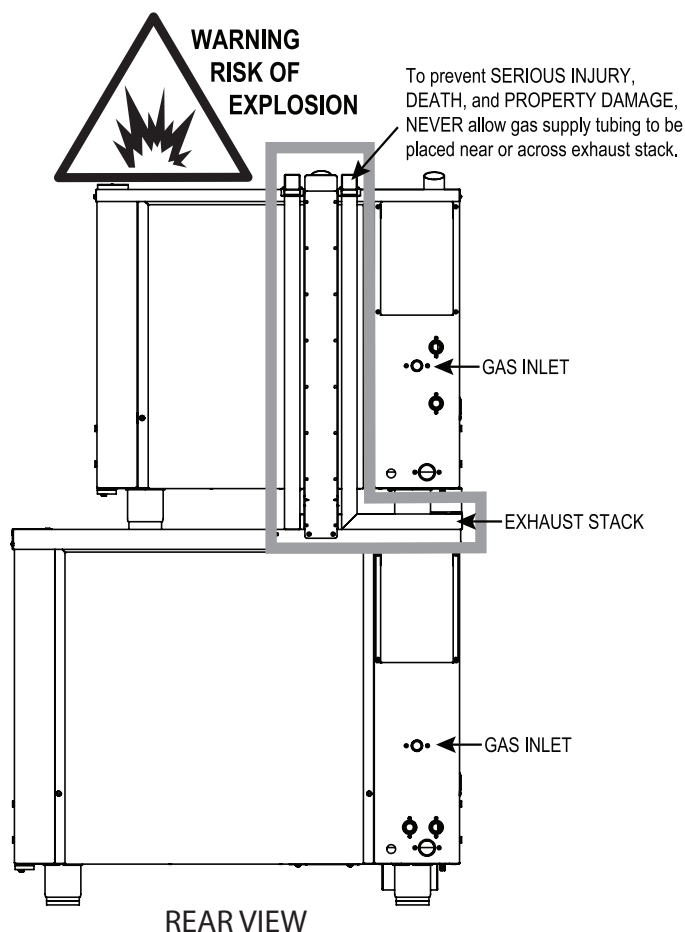

## GAS SUPPLY AND INSTALLATION

### GAS LEAK TESTING

If a pressure leak test above 1/2 psi (34.5 mbar) is to be performed on the building supply gas piping, the shut-off gas valve and oven inlet gas supply line must be disconnected from the building supply piping before conducting the pressure test. Failure to do so may result in damage to the manual gas valve, gas components in the oven, or both.

If any gas leak tests are to be conducted at pressures equal to or below 1/2 psi (34.5 mbar), the manual gas shut-off valve upstream of the oven must be turned off before conducting the tests.

Leak testing of the internal oven piping system was conducted before shipping the oven from the factory. If additional testing is needed, it should only be conducted at normal gas supply pressures. If the testing is performed using combustible gas in the piping, the leak checking should be done with a soap solution (bubble checking).

The use of an electronic combustible gas leak detector is helpful, however, this type of detector can be oversensitive. Electronic detectors may indicate false leaks from other sources which would not be detected when checking with a liquid solution to verify a no-hazard gas connection.

When starting the oven after initial installation, the gas lines must be free of air. It may take up to 30 minutes to eliminate all air from the lines. If, after this time there is no heat, call for factory assistance.

### GAS EXHAUST

The oven is not designed for direct connection to a chimney vent system or for direct connection to a horizontal exhaust system.

The oven must be installed under a ventilation hood.

Oven operators should be instructed with regard to the hazards of placing any material on top of the oven that would obstruct the flow of flue products out the opening of the flue diverter. Operators should also be instructed with regard to the hazards of hot flue gases and that any material or items placed on top of, or in front of the flue deflector could be damaged or cause a fire hazard.

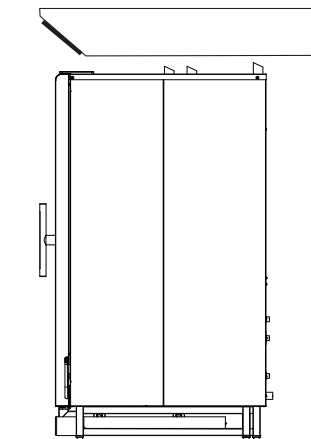

## WARNING



Never use an open flame or other ignition sources to check for gas leakage. Failure to do so may cause a fire or explosion and result in serious injury or death.

## DANGER



Explosion hazard. Before starting the appliance, make certain you do not detect the odor of gas.

If you smell gas:

- Shut off the gas supply immediately.
- Do not attempt to light any appliance.
- Do not touch any electrical elements.
- Extinguish any open flame.
- Evacuate the area.
- Use a telephone outside the property and immediately contact your gas supplier.
- If unable to contact your gas supplier, contact the fire department.

## WARNING



**DO NOT** obstruct or block exhaust flues or attach any flue extension that may impede proper burner operation, restrict the exhaust fumes and cause negative backdraft or the appliance to shut down. Failure to do so may result in serious injury or death.

**WATER QUALITY REQUIREMENTS**

**Water Quality Requirements**

**Use a drinking quality, cold water supply only.**

 <b>WARNING</b>
Significant damage to the appliance cavity, elements, or heat exchanger could result from improper water quality. Failure to meet the water quality requirements and observe this precaution will void the warranty.

Water quality is of critical importance when installing steam producing equipment of any kind, particularly high temperature steam producing equipment. Water that is perfectly safe to drink is composed of chemical characteristics that directly affect the metal surfaces of steam producing equipment. These chemical characteristics differ greatly from region to region throughout the U.S. and the world. Varying combinations of pH; alkalinity; hardness; chlorides; total dissolved solids; and other chemical characteristics, when subjected to high temperatures, will cause water to have a tendency to either scale or corrode.

Alto-Shaam has consulted with people who understand the properties of water in order to provide water quality standards that meet the broadest possible range of acceptable water quality requirements to help protect your investment.

We strongly urge water testing to ascertain the water quality on site prior to the installation of any steam producing equipment. Since water quality is an important issue, Alto-Shaam is committed to provide as much information as possible to help protect the investment made in this equipment.

A water filtration system, when properly installed, maintained, and combined with the required levels of steam producing equipment maintenance, will help lessen the affect water has on metal surfaces. It will not, however, provide complete protection against all water damage from region to region.

Due to the complexity of water chemistry, it is important to understand that water quality plays a significant role in the longevity of steam producing equipment. Water quality and required maintenance of steam generating equipment is the direct responsibility of the owner/operator. Damage incurred as a direct result of poor water quality and/or surfaces affected by water quality is also the responsibility of the owner/operator. Damage due to water quality that does not meet the minimum standards shown below is not covered under the Alto-Shaam Combitherm warranty.

Contaminant	Inlet Water Requirements
Free Chlorine	Less than 0.1 ppm (mg/L)
Hardness	30-70 ppm
Chloride	Less than 30 ppm (mg/L)
pH	7.0 to 8.5
Silica	Less than 12 ppm (mg/L)
Total Dissolved Solids (tds)	Treated line: 50-125 ppm
	Untreated line: 50-360 ppm

It is the sole responsibility of the owner/operator/purchaser of this equipment to verify that the incoming water supply is comprehensively tested and if required, a means of “water treatment” provided that would meet compliance requirements with published water quality standards. Non-compliance with these minimum standards will potentially damage this equipment and/or components and VOID the original equipment manufacturer’s warranty. Alto-Shaam recommends using OptiPure® [www.optipurewater.com] products to properly treat your water.

Alto-Shaam will continue our efforts to provide viable solutions to ease the impact of water quality as it relates to heat producing equipment.



**Notice:** To prevent water pipes from bursting, the incoming water supply should be off when the appliance is not in use.



**Notice:** Verify that the water supply is open before starting the cleaning program.

## WATER SUPPLY AND INSTALLATION

### WARNING

Significant damage to the appliance cavity, elements, or heat exchanger could result from improper water quality. Failure to meet the water quality requirements and observe this precaution will void the warranty.

- Flush the water line at the installation site.
- **Backflow Prevention** — The equipment must be installed with a check-valve or other anti-backflow/anti-siphon device on all inlet water lines in accordance with and as required by national, state, and local health, sanitation and plumbing codes.
- **PIPE SEALING TAPE (Teflon®) MUST BE USED AT ALL CONNECTION POINTS.** The use of a pipe sealing compound is not recommended.
- Install a manual water shut-off valve between the main cold water supply line(s) and Combi supply lines.

### WARNING

Bursting water supply lines may cause serious injury or flooding. Always turn OFF incoming water supply valves when the oven is not in use.

#### NOTICE:

Untreated water supplies will permanently damage the water system in this oven. Two water supplies are required for proper operation. At least one **MUST** be treated.

Supply lines should be flexible to allow oven to be moved when service or cleaning is needed.

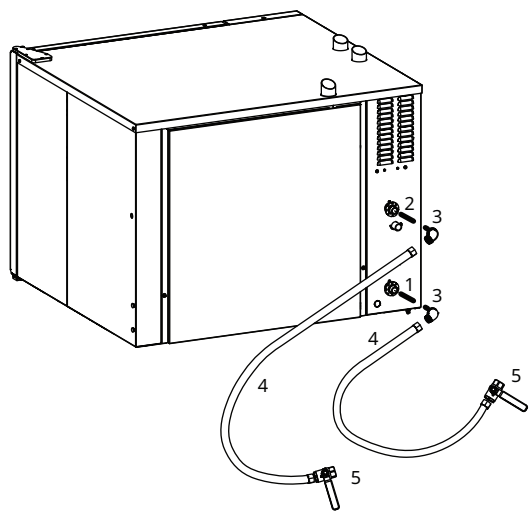
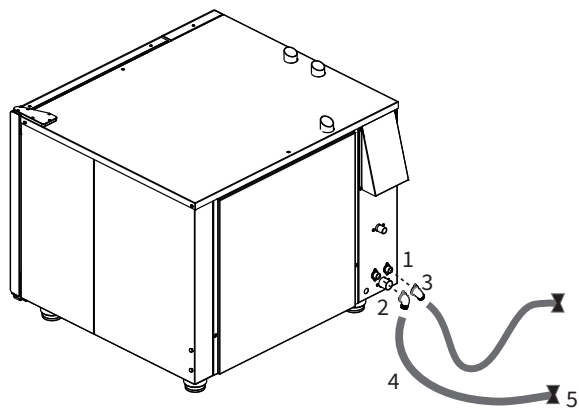

- |  |                                 |
|--|---------------------------------|
| 1. Untreated water inlet                                       | 5. Shut-off valve               |
| 2. Treated water inlet   | 6. Check Valve (inspect yearly) |
| 3. Install a 90° fitting whenever possible on each water line. | 7. Manifold                     |
| 4. Connect a flexible water line to each inlet fitting.        | 8. Filter                       |

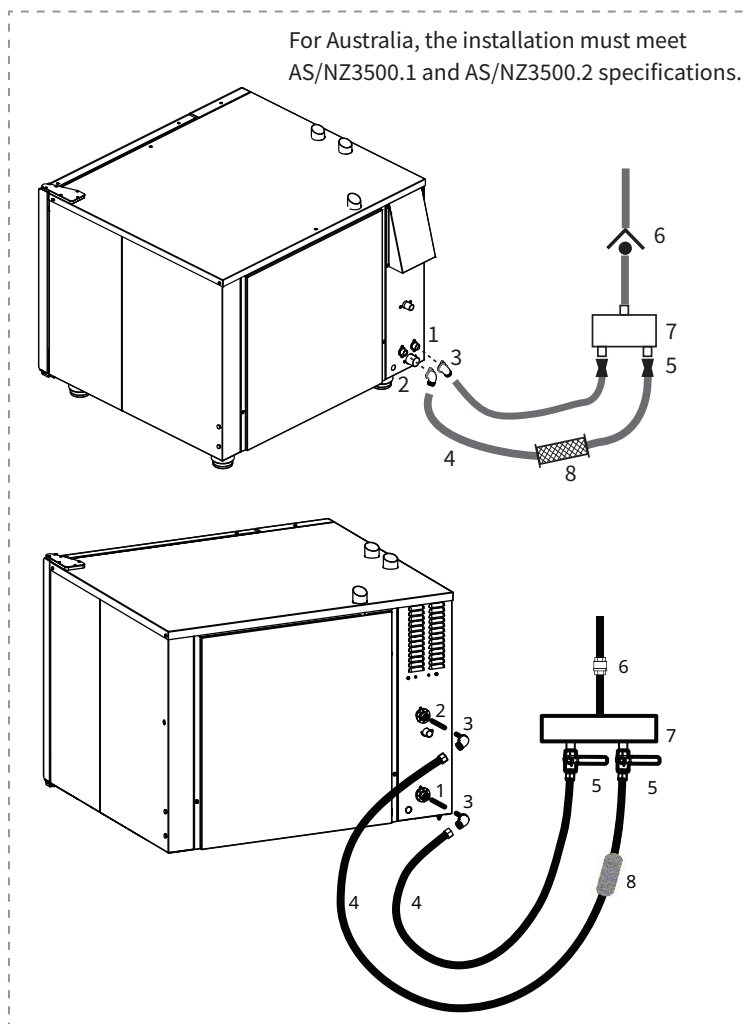

**WATER DRAINAGE – FOR SINGLE OVEN**

A union is required. Install a 1-1/2-inch (40mm) diameter connection, drain line and clamp into place. The drain line must always be a positive gradient away from the Combitherm oven. An end of drain run air gap may be required by local code. Vertical air vent required.

**NOTICE:** In the U.S.A., this equipment is to be installed to comply with the Basic Plumbing Code of the Building Officials and Code Administrators International, Inc. [BOCA], and the Food Service Sanitation Manual of the Food & Drug Administration [FDA].

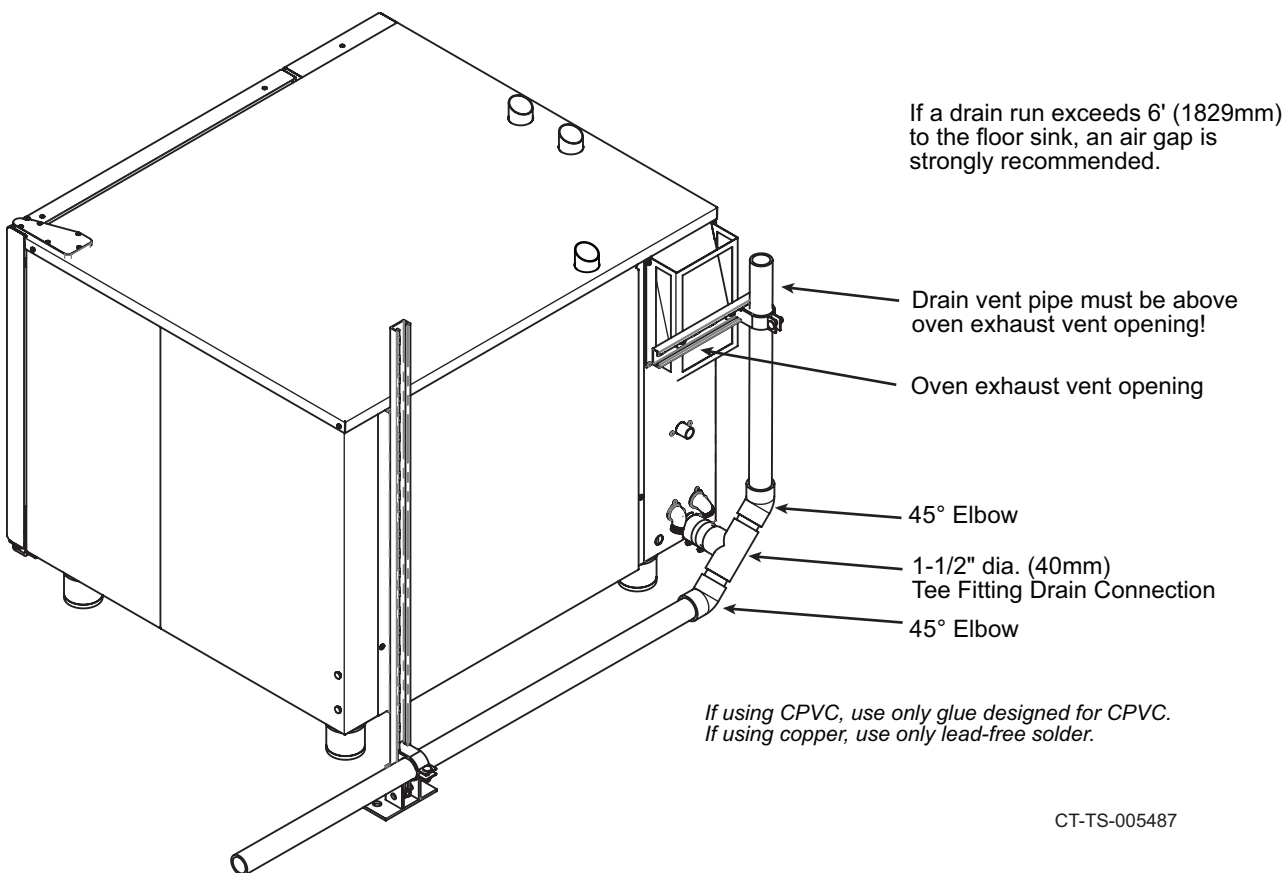

**SPECIAL NOTES FOR WHEN STACKING DISSIMILAR UNITS**

When installing two dissimilar units, for example, a CTP 7-20 over a VMC-F4, consult the specification sheet of each unit for the required clearances. Always use the largest clearance dimension when a choice between two competing dimensions needs to be made.

Always plumb the units in such a way that does not inhibit the ability to remove access panels, clean filters, or install the utilities of the companion unit.

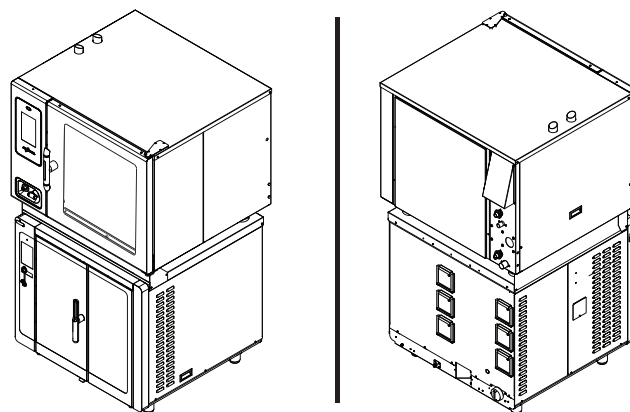

## WATER DRAINAGE – FOR SINGLE OVEN (Rear Panel with Louver)

A union is required. Install a 1-1/2-inch (40mm) diameter connection, drain line and clamp into place. The drain line must always be a positive gradient away from the Combitherm oven. An end of drain run air gap may be required by local code. Vertical air vent required.

**NOTICE:** In the U.S.A., this equipment is to be installed to comply with the Basic Plumbing Code of the Building Officials and Code Administrators International, Inc. [BOCA], and the Food Service Sanitation Manual of the Food & Drug Administration [FDA].

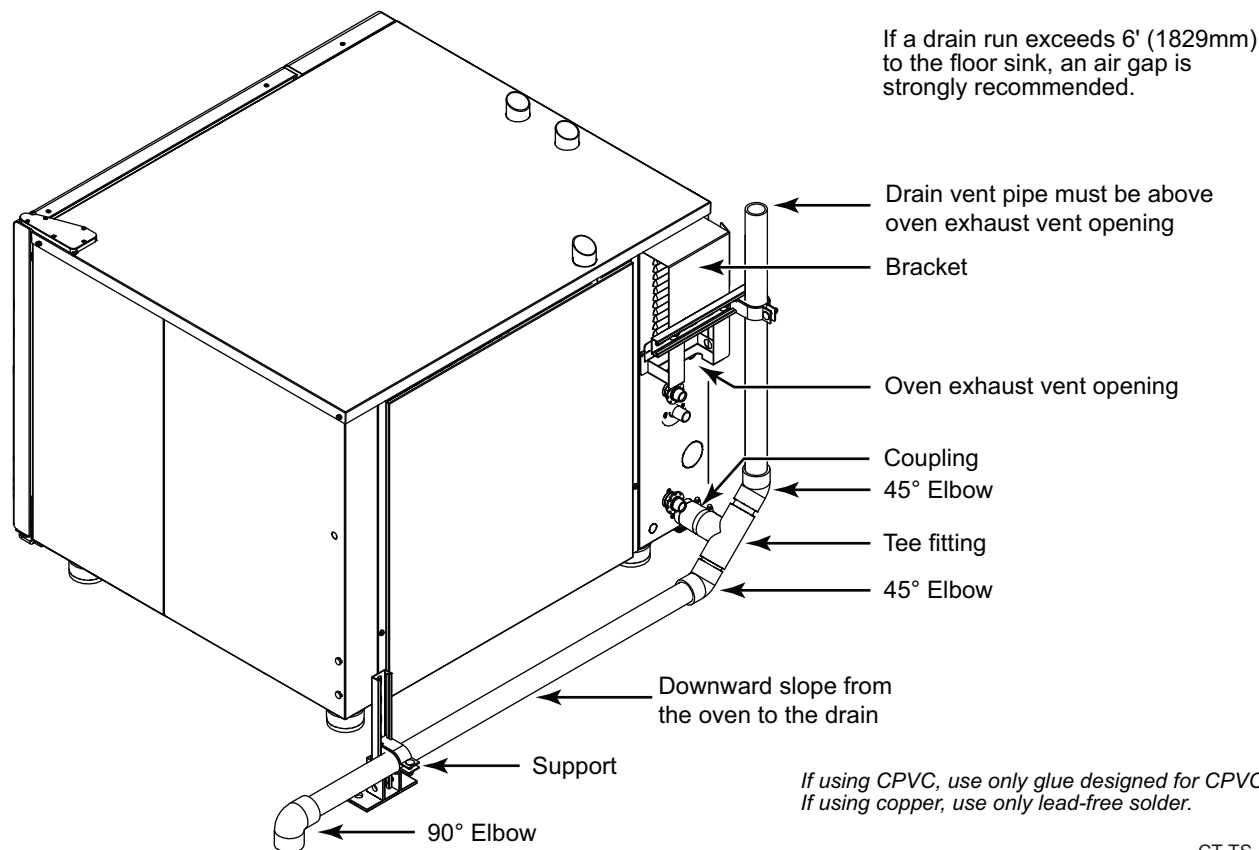

CT-TS-015289

## SPECIAL NOTES FOR WHEN STACKING DISSIMILAR UNITS

When installing two dissimilar units, for example, a CTP 7-20 over a VMC-F4, consult the specification sheet of each unit for the required clearances. Always use the largest clearance dimension when a choice between two competing dimensions needs to be made.

Always plumb the units in such a way that does not inhibit the ability to remove access panels, clean filters, or install the utilities of the companion unit.

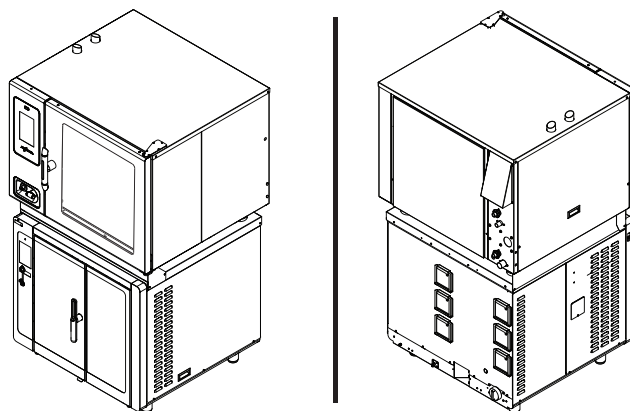

**WATER DRAINAGE – FOR STACKED OVEN**

A union is required. Install a 1-1/2-inch (40mm) diameter connection, drain line and clamp into place. The drain line must always slope downwards away from the Combitherm oven. An end of drain run air gap may be required by local code. Vertical air vent required.

**NOTICE:** In the U.S.A., this equipment is to be installed to comply with the Basic Plumbing Code of the Building Officials and Code Administrators International, Inc. [BOCA], and the Food Service Sanitation Manual of the Food & Drug Administration [FDA].

**⚠ WARNING**



Slippery when wet. To prevent serious injury or property damage, make sure drain is properly connected and not blocked.

Local codes may require that the type of material used for the drain pipes be different than the CPVC pipes provided in the installation kit. In such cases, any costs associated with changing the drain pipes to meet the local codes are the responsibility of the end user.

Installation kits have a maximum run length of 4-1/2' (1372mm).

**One suggested method of drain installation.**

Drain materials must withstand temperatures up to 200°F (93°C).

If a drain run exceeds 6' (1.8m) to the floor sink, an air gap is strongly recommended.

When stacking ovens, run independent drains.

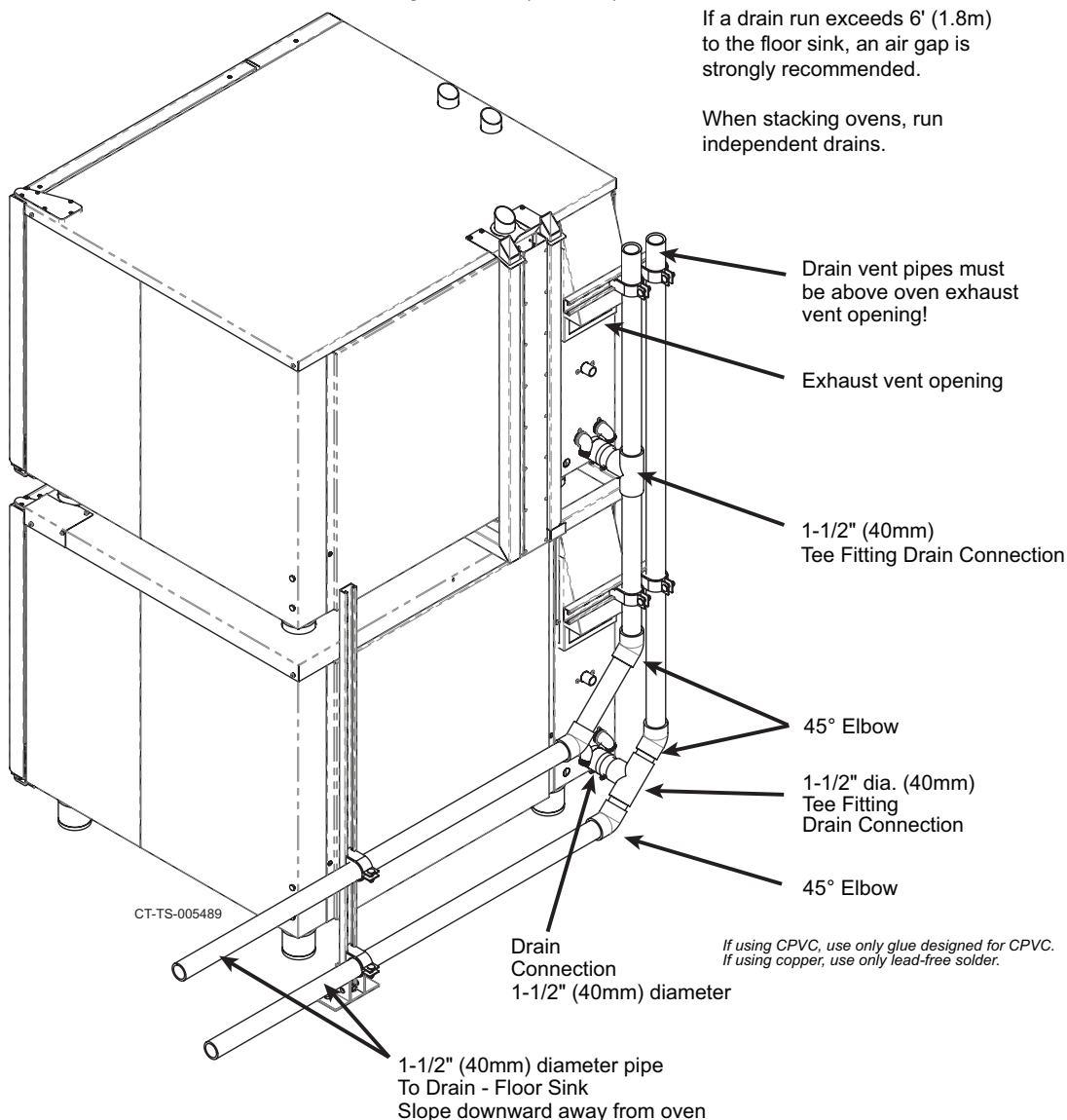

## WATER DRAINAGE – FOR STACKED OVEN (Rear Panel with Louver)

A union is required. Install a 1-1/2-inch (40mm) diameter connection, drain line and clamp into place. The drain line must always slope downwards away from the Combitherm oven. An end of drain run air gap may be required by local code. Vertical air vent required.

**NOTICE:** In the U.S.A., this equipment is to be installed to comply with the Basic Plumbing Code of the Building Officials and Code Administrators International, Inc. [BOCA], and the Food Service Sanitation Manual of the Food & Drug Administration [FDA].

**⚠ WARNING**



Slippery when wet. To prevent serious injury or property damage, make sure drain is properly connected and not blocked.

Local codes may require that the type of material used for the drain pipes be different than the CPVC pipes provided in the installation kit. In such cases, any costs associated with changing the drain pipes to meet the local codes are the responsibility of the end user.

Installation kits have a maximum run length of 4-1/2' (1372mm).

### One suggested method of drain installation.

Drain materials must withstand temperatures up to 200°F (93°C).

If a drain run exceeds 6' (1.8m) to the floor sink, an air gap is strongly recommended.

When stacking ovens, run independent drains.

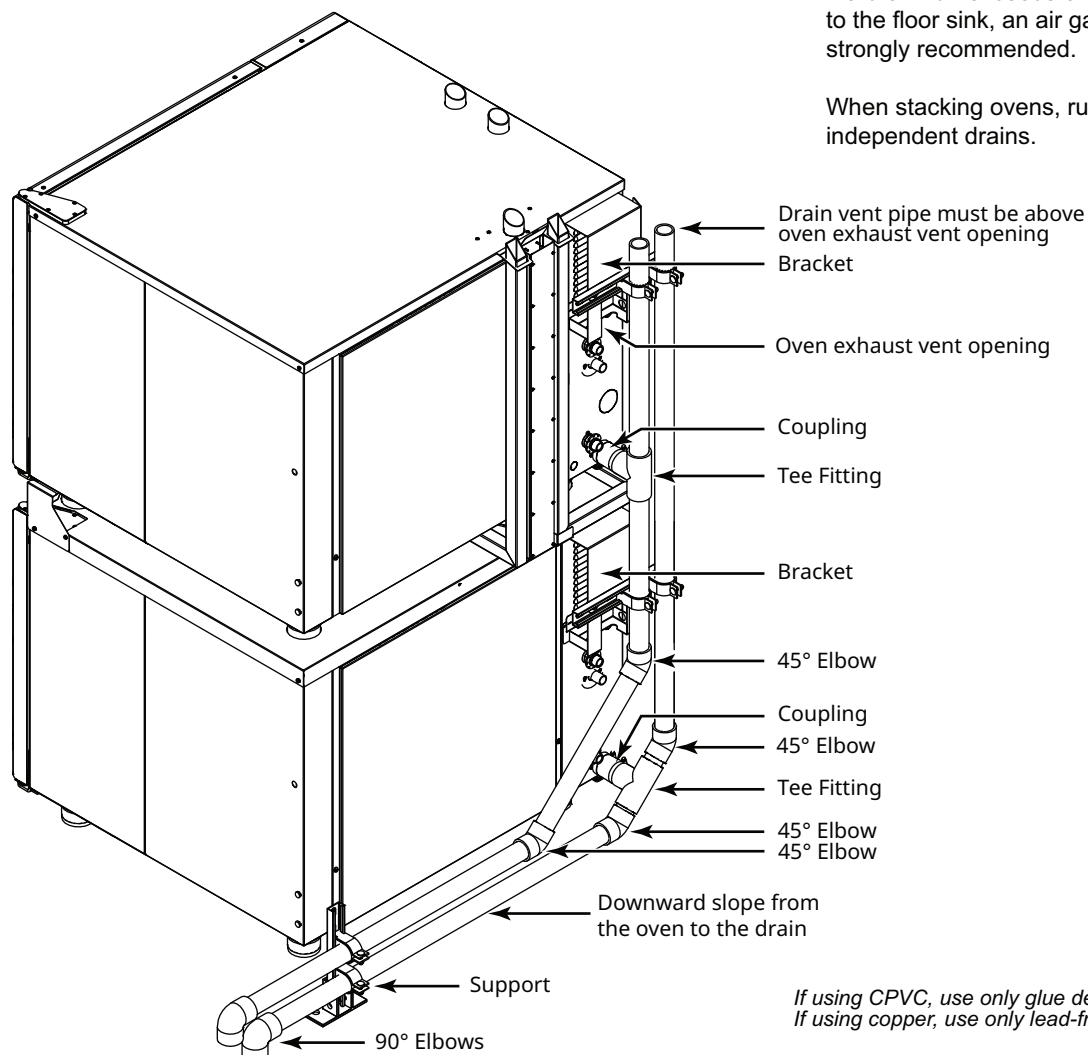

*If using CPVC, use only glue designed for CPVC.  
If using copper, use only lead-free solder.*

## MOBILE EQUIPMENT RESTRAINT

**For Gas Models:**

The gas Combitherm must use a connector that complies with The Standard for Connectors for Movable Gas Appliances, ANSI Z21.69 CSA 6.16 and addenda Z21.69a-1989. A quick disconnect device must be installed to comply with The Standard for Quick Disconnect Devices for Use with Gas Fuel, ANSI Z21 CSA 6.9. and European Standard EN203.

Adequate means must be provided to limit the movement of this appliance. Limitation of movement must be made without depending on the connector, the quick disconnect device, or the associated piping designed to limit appliance movement. If it becomes necessary to disconnect the restraint, it must be reconnected immediately following the return of the appliance to its original position.

1. Install a manual gas shut-off valve along with an approved disconnect device.
2. Install an A.G.A. certified, heavy-duty connector that complies with ANSI Z 21.69 or CAN 1-6.10m88 along with a quick-disconnect device in compliance with ANSI Z21.41 or CAN 1-6.9m70. Connectors must be installed with a cable restraint to prevent excessive tension from being placed on the connector.

**FIRE HAZARD**

To prevent SERIOUS INJURY or DEATH, your appliance must be secured to building structure to prevent unintended movement.

**For Electric Models:**

This section is provided for the assistance of qualified and trained service technicians only and is not intended for use by untrained or unauthorized service personnel. Failure to observe this precaution may void the warranty.

**WARNING**

ELECTRIC SHOCK HAZARD.

To prevent SERIOUS INJURY or DEATH, your appliance must be secured to building structure to prevent unintended movement.

Any appliance that includes a set of casters must be installed with a tether. Adequate means must be provided to limit the movement of this appliance without depending on or transmitting stress to the electrical conduit. The following requirements apply:

1. Casters must be a maximum height of 6" (152mm).
2. Two of the casters must be the locking type.
3. Such mobile appliances or appliances on mobile stands must be installed with the use of a flexible connector secured to the building structure.

A mounting connector for a restraining device is located on the lower back flange of the appliance chassis or on an oven stand, approximately 18" (457mm) from the floor. A flexible connector is not supplied by, nor is it available from, the factory.

**NOTICE: The mobile base used on stacked ovens is not adjustable. The equipment must be placed on a stable, non-combustible, level, horizontal surface.**

## **SPECIAL CONDITIONS FOR UNITS INSTALLED WITHIN THE CITY OF NEW YORK**

1. Installation and start up must be performed by an Alto-Shaam authorized installation company.
2. Operating instructions in the manual must be read and understood by all persons using the appliance. The person responsible for training of the operators is responsible for the safekeeping of the manual.
3. A ventless hood condensate drain line to the floor drain shall be installed as applicable. The drain line must always be a positive gradient away from the Combitherm.
4. The grease filter(s) shall be cleaned at least once a week. The disposable dry-type air filter(s) should be inspected for contaminants on a regular basis. Replacement must be made at a minimum of three month intervals. A hood maintenance log must be included with the unit and shall be completed at the intervals indicated.
5. The filter interlocks shall be inspected/tested at least every 6 months.
6. Suitable fire protection shall be provided for each installation. This protection system is subject to FDN Range Hood Inspection Unit's inspection and approval.
7. Installation, maintenance, and cleaning procedures shall comply with all applicable New York City Fire Code, New York City Electric Code, Land Construction Codes (including the Building Code and the Mechanical Code) rules and regulations.
8. Underwriters Laboratories, Inc.'s listing requirements and limitations shall be complied with and manufacturer's installation procedures, maintenance procedures, and safety limitations shall be complied with.
9. The ductless hood and Combitherm unit shall be used for light duty cooking only and the entire ductless hood on a combi oven with grease filter I air filter shall be inspected, cleaned, and replaced if necessary by qualified person holding a Certificate of Fitness type W-64 or F-64. A record of such inspection and cleaning shall be kept on the premises for inspection.
10. The Certificate of Approval number shall be plainly and permanently labeled upon the appliance.
11. All installations shall be subject to inspection by representatives of the Bureau of Fire Prevention which may result in added requirements being imposed.
12. The Fire Department reserves the right to make periodic inspections of the above referenced ductless hood on a combi oven without warning to ensure that maintenance requirements are being followed. These audit inspections will be solely at the discretion of the Fire Department.

### **How to test the filter interlocks**

1. Set the oven to Convection cook a 350°F for two minutes and 30 seconds.
2. Verify that the hood is operating. There should be no error codes and hood fan will be running and audible.
3. With approximately two minutes remaining in the cook cycle, the fan will shift to high speed. This shift in fan speed will be audible.
4. Remove the left grease filter from the hood. Confirm that the control displays E101 or E102 error codes. In stacked configurations, both controls will display the error codes. Re-install the filter and clear the error codes.
5. Repeat Step 4 with the right grease filter.

LIQUID CLEANER HOOK-UP (IF EQUIPPED WITH THIS OPTION)

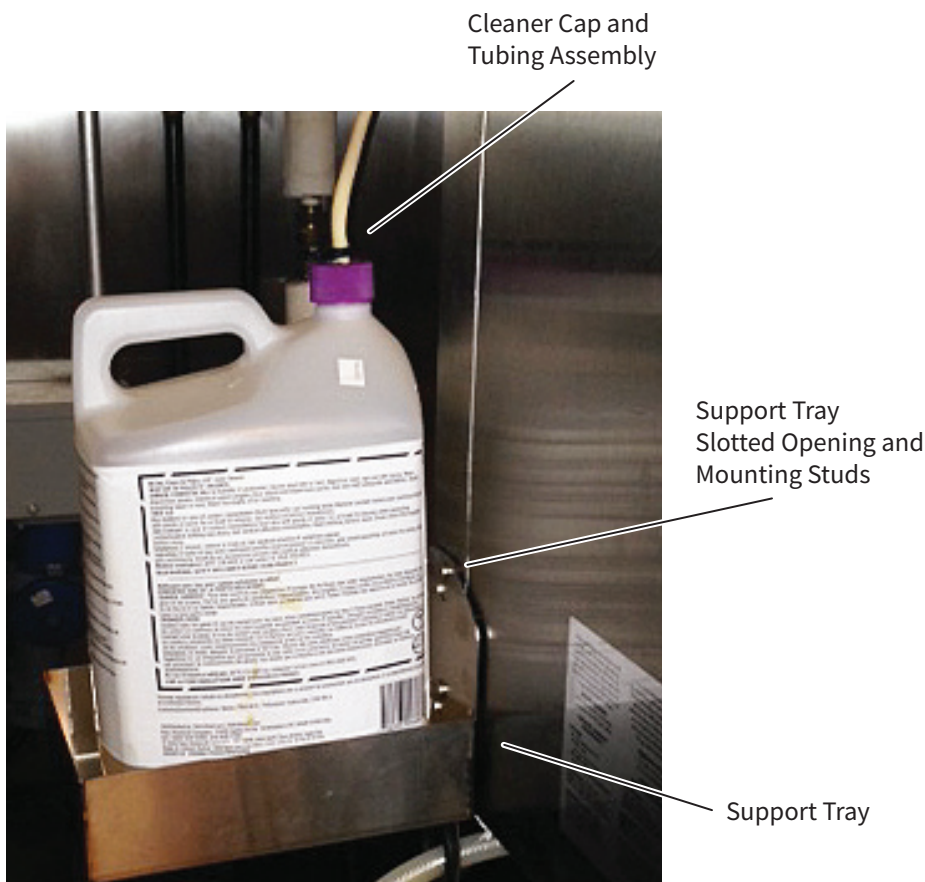

- Removable, cleaner support tray can be mounted on the left or right exterior wall of the oven. Slide slotted openings on the tray over the mounting studs.
- Support tray holds a 2-1/2-gallon (9,5 liter) bottle and measures 10-1/2" x 7-3/4" (267mm x 194mm).
- Place liquid oven cleaner bottle inside tray.
- Wearing protective rubber gloves and eyewear, remove cap from liquid oven cleaner bottle. Pull out the Cleaner Cap and Tubing Assembly from the back of the unit, and screw onto liquid oven cleaner bottle.
- Position cap to ensure the hose is not kinked after tightening.
- Combitherm liquid oven cleaner jugs are quickly and easily replaced.
- Combitherm liquid oven cleaner is automatically pumped through the system, saving labor and providing greater employee safety by eliminating the need to handle caustic cleaning liquids each day.

**! WARNING**

ALWAYS wear protective eyewear and rubber gloves when using liquid oven cleaner to prevent eye, skin, and respiratory tract irritation.

Keep out of reach of children.

See Safety Data Sheet for additional information.

**! WARNING**

To prevent SERIOUS INJURY or DEATH, NEVER operate this appliance in a cleaning mode without the liquid cleaner connected, with a kink in the cleaning hose line, or with an empty liquid cleaner container. Failure to do so may result in poor oven cleaning, grease and/or carbon accumulating inside the oven cavity and increased risk of fire.

**! WARNING**

To prevent **serious personal injury, death, or property damage:**

The appliance must be cleaned thoroughly to avoid deposits of grease and or food residues inside the appliance that may catch fire. If fat deposits and/or food waste inside the appliance ignite, shut down the appliance immediately and keep the appliance door closed to extinguish the fire. If further extinguishing is required, disconnect the appliance from the main power and use a fire extinguisher (do not use water to extinguish a grease fire!). Failure to clean the appliance properly invalidates the warranty and relieves Alto-Shaam of all liability.

## GREASE COLLECTION INSTALLATION (IF EQUIPPED WITH THIS OPTION)

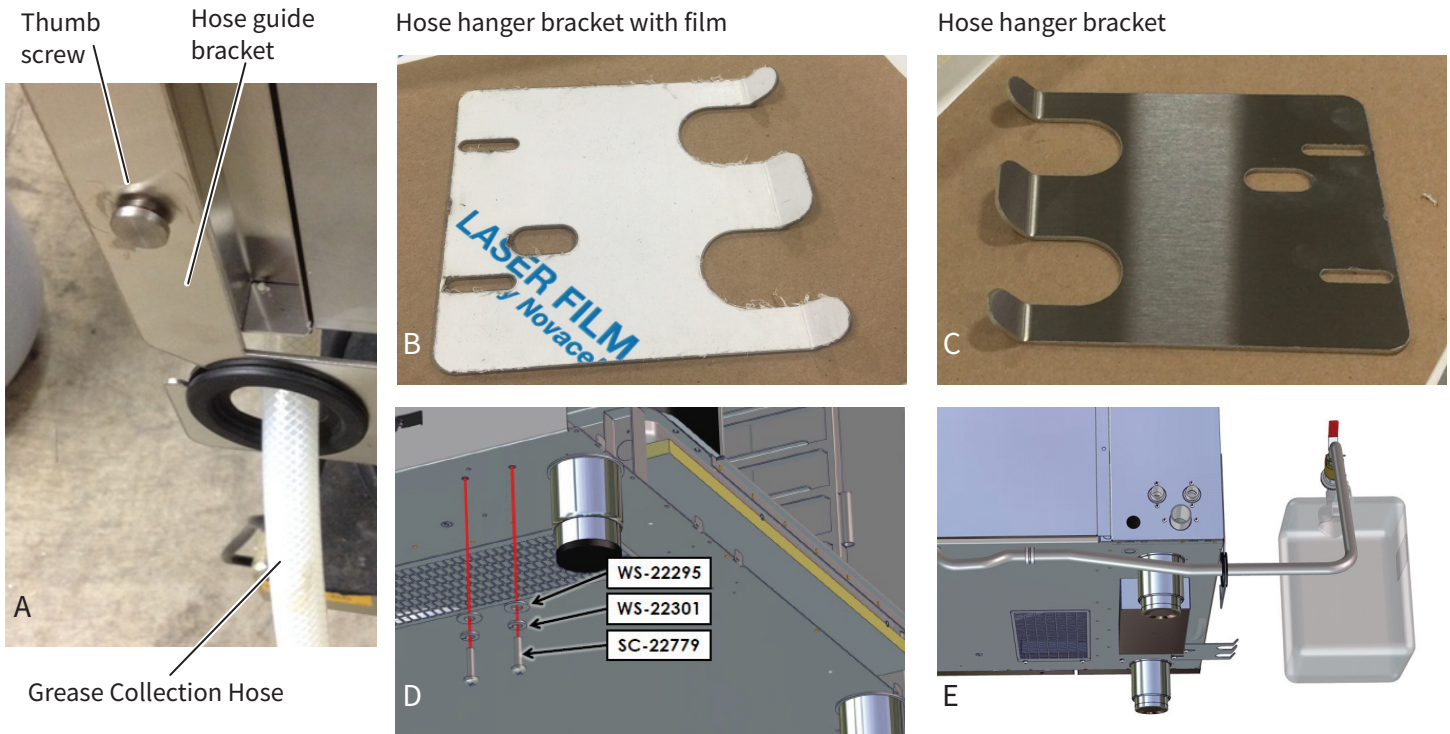

- Grease Collection Hose Assembly is attached to the oven in the back.
- The hose guide bracket can be attached on either the left side or the right side toward the back. **Placement on the left side is recommended whenever possible.** Thumb screws are in position for this purpose. Remove thumb screws, position hose guide bracket and secure screws (PHOTO A). Thread grease hose through the guide.
- The hose hanger bracket can be attached on either the left side or the right side toward the front of the oven. **Placement on the left side is recommended whenever possible.** Remove the plastic protective film from the bracket (PHOTO B,C). Pan head screws are in position beneath the oven for this purpose. **For stacked configurations, always place the hanger bracket on bottom of the top oven.** Remove pan head screws and washers (PHOTO D), position hose hanger bracket on either side of the oven and secure screws and washers (PHOTO E,F). The hanger bracket is used to secure the grease collection hose while changing grease collection containers.
- Place Grease Collection Containers inside the tray of the Mobile Grease Collection Cart. Roll into place next to the oven and **apply the caster brake.**
- **Loosen vent cap on container.** Pull out the Grease Collection Hose Assembly from the back of the unit. Remove collection container fill cap (PHOTO G).
- Screw Grease Collection Hose Assembly on to collection container until snug.
- Turn ball valve handle to the **ON** position.

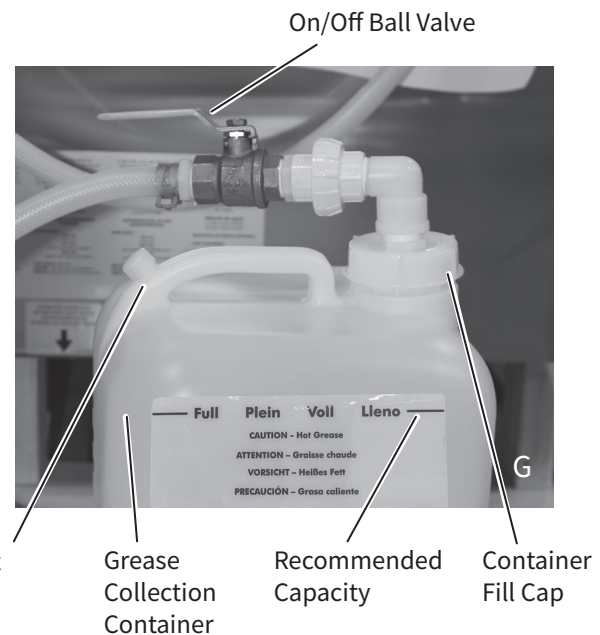

## How To Turn On the Appliance

### Before you begin

1. Turn on the exhaust hood.
2. Make sure that the water supply to the appliance is turned on.
3. Make sure that the electrical power supply to the appliance is turned on.
4. For gas appliances, make sure the gas supply valve is in the open position.

### Steps

1. Press the ON/OFF button .

The ON/OFF indicator glows green and the loading screen ① displays while the controller software loads. When the software is 100% loaded, the home screen ② displays.

**NOTE:** If the appliance has a steam generator, the steam generator fills with water and the appliance heats the water to an initial temperature of 188°F (77°C).

## How To Start a Manual Calibration

1. Make sure the appliance is off.
2. Press and hold the ON/OFF button  for eight (8) seconds. The ON/OFF indicator glows red and the calibration prompt ③ displays.

The prompt moves from the center to all four corners of the screen. This sequence repeats three (3) times. Then the calibration screen ④ displays.

**NOTE:** The first time the appliance is turned on, or if the appliance loses power during startup, the touchscreen calibration prompt ③ displays at the end of the next startup.

**NOTE:** Touch the check mark icon  to start calibration immediately. Touch the cancel icon  to cancel calibration.

## How To Calibrate the Touchscreen

1. Touch the target icon (+) each time it appears on screen. The icon appears in all four corners, then the center of the screen.

**NOTE:** If the controller software has not been updated to the current version, calibration stops when this step is complete. Download the current controller software from the Alto-Shaam website and install it.

2. The verification screen ⑤ displays. Touch all five target icons . The icons change to green boxes when they are touched.

**NOTE:** The calibration screen and verification screen both display a 30-second countdown. If you do not touch all five icons before the countdown is complete, the controller stops calibration. If you do not see the countdown, download the current controller software from the Alto-Shaam website and install it.

## How To Turn Off the Appliance

1. Press and hold the ON/OFF button  for five to ten (5-10) seconds.

## DANGER



Before starting the appliance, make certain you do not detect the odor of gas.

If you smell gas:

- Shut off the gas supply immediately.
- Do not attempt to light any appliance.
- Do not touch any electrical elements.
- Extinguish any open flame.
- Evacuate the area.
- Use a telephone outside the property and immediately contact your gas supplier.
- If unable to contact your gas supplier, contact the fire department.

## CAUTION



Accumulations on the main burners of gas appliances can result in firing out of normal sequence. This delayed ignition creates an alarmingly loud sound. If your appliance makes an especially loud noise when starting up, shut down the appliance and call a qualified and trained service technician.

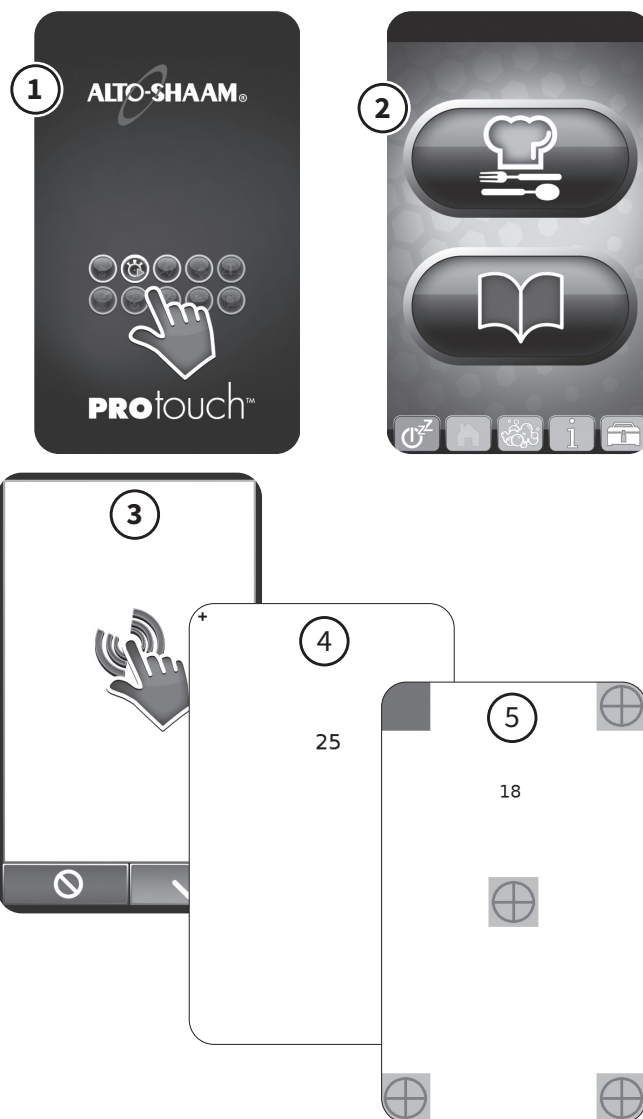

## How To Run a Cycle Test of the Appliance

### Run the cycle test in combination cook mode

1. Touch the professional cooking mode icon ① in the home screen. The cooking screen displays.
2. Touch the icon for the combination cook mode ②.
3. Touch the displayed temperature ④.  
The touchpad displays.
4. If necessary, use the number keys ⑧ to set the cooking temperature to 350°F (177°C), then touch the check mark icon ⑨.
5. Touch the displayed time ⑤. The touchpad screen displays.
6. Use the number keys ⑧ to enter the cooking time (00:15:00), then touch the check mark icon ⑨.
7. Touch the start icon ⑥. The start icon changes to a red square (stop icon) and the appliance begins cooking.
8. Make sure that the appliance cycles correctly.
  1. The appliance raises the cavity temperature to the set temperature.
  2. The appliance cycles off by itself when the set temperature is reached.
  3. The appliance idles until the cavity temperature drops below the set temperature.
  4. The appliance cycles back on by itself until the cavity temperature again reaches the set temperature.

Allow the appliance to run through several cycles.

### Cool down the appliance

1. Touch the stop icon ⑥ to stop the cooking process.
2. Touch the cool down icon ⑦. The touchpad screen displays.
3. Use the number keys ⑧ to set the cool down temperature to 110°F (43°C).
4. Open the appliance door.
5. Touch the check mark icon ⑨. The fan activates.  
The cool down screen (not shown) displays the cavity temperature at the top and the cool down temperature at the bottom.  
The fan turns off when the cavity temperature matches the set cool down temperature.

### Run the cycle test in convection cook mode

1. Touch the icon for the convection cook mode ③.
2. Repeat the cycle test steps for convection cook mode.
3. Cool down the appliance when the cycle test is complete.

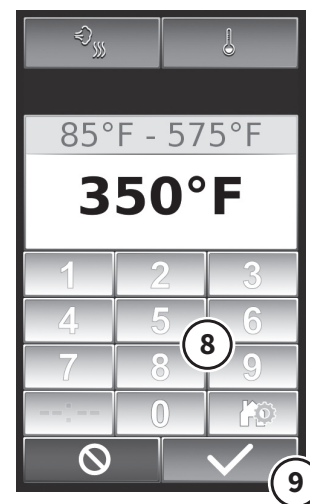

## How To Turn On the Appliance

### Before you begin

1. Turn on the exhaust hood.
2. Make sure that the water supply to the appliance is turned on.
3. Make sure that the electrical power supply to the appliance is turned on.
4. For gas appliances, make sure the gas supply valve is in the open position.

### Steps

1. Press the ON/OFF button ①. The ON/OFF indicator glows green.

**NOTE:** If the appliance has a steam generator, the steam generator fills with water and the appliance heats the water to an initial temperature of 188°F (77°C).

**NOTE:** To power off the appliance, press and hold the Power button for 5 to 10 seconds to initiate the power shutdown sequence to the oven.

## How To Run a Cycle Test of the Appliance

### Run the cycle test in combination cook mode

2. Press the combination cook mode button ②.
3. Press the cook temperature button ③.
4. If necessary, use the up arrow button ⑤ or the down arrow button ⑨ to set the cooking temperature to 350°F (177°C).
5. Press the cook time button ④.
6. Use the up arrow button ⑤ or the down arrow button ⑨ to enter the cooking time (00:15:00).
7. Press the start/stop button ⑩. The appliance begins cooking.
8. Make sure that the appliance cycles correctly.
  1. The appliance raises the cavity temperature to the set temperature.
  2. The appliance cycles off by itself when the set temperature is reached.
  3. The appliance idles until the cavity temperature drops below the set temperature.
  4. The appliance cycles back on by itself until the cavity temperature again reaches the set temperature.

Allow the appliance to run through several cycles.

### Cool down the appliance

1. Press the start/stop button ⑩ to stop the cooking process.
2. Press the cool down button ⑦.
3. Use the up arrow button ⑤ or the down arrow button ⑨ to set the cool down temperature to 110°F (43°C).
4. Open the appliance door.

**NOTE:** The cook time field ⑧ displays “dOOr” if the door is not open.

## DANGER



Before starting the appliance, make certain you do not detect the odor of gas.

If you smell gas:

- Shut off the gas supply immediately.
- Do not attempt to light any appliance.
- Do not touch any electrical elements.
- Extinguish any open flame.
- Evacuate the area.
- Use a telephone outside the property and immediately contact your gas supplier.
- If unable to contact your gas supplier, contact the fire department.

## CAUTION



Accumulations on the main burners of gas appliances can result in firing out of normal sequence. This delayed ignition creates an alarmingly loud sound. If your appliance makes an especially loud noise when starting up, shut down the appliance and call a qualified and trained service technician.

**NOTICE:** In the event of a power failure, the oven will not operate.

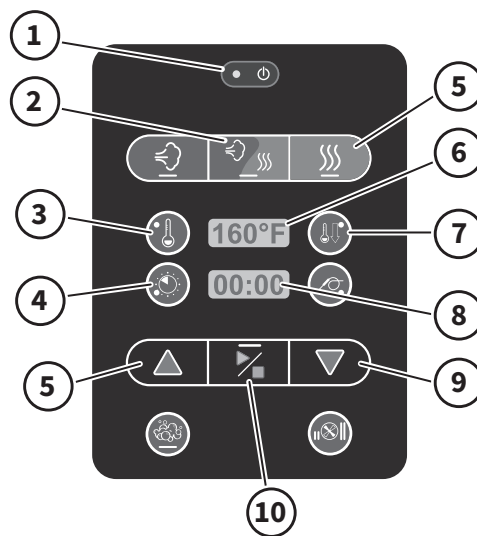

5. Press the start/stop button ⑩. The fan activates. The cook time field ⑧ displays the cavity temperature. The fan turns off when the cavity temperature matches the set cool down temperature.

### Run the cycle test in convection cook mode

1. Press the convection cook mode button ⑤.
2. Repeat the cycle test steps for convection cook mode.
3. Cool down the appliance when the cycle test is complete.

# Inspection Checklist



## Daily Inspection

### Unit Information

Business Name: \_\_\_\_\_

Serial Number: \_\_\_\_\_

Model Number: \_\_\_\_\_

Daily Inspection Start Date: \_\_\_\_\_

### Daily Inspection Checklist

	Monday	Tuesday	Wednesday	Thursday	Friday	Saturday	Sunday
Inspect and clean:							
Product probe (thermometer)							
Door gasket (inner door seal)							
Inner door glass							
Front drip tray							
Screen and overlay (inspect for cracks, peeling, moisture, etc.)							
Execute automatic wash cycle (with approved cleaning chemical ONLY)							
Employee initials							

### Component Malfunction and Replacement

List details of the failure(s) next to the day they occurred. Leave blank if components are working properly.	
Monday	
Tuesday	
Wednesday	
Thursday	
Friday	
Saturday	
Sunday	

## Weekly Inspection

### Unit Information

**Business Name:** \_\_\_\_\_

**Serial Number:** \_\_\_\_\_

**Model Number:** \_\_\_\_\_

**Weekly Inspection Start Date:** \_\_\_\_\_

### Weekly Inspection Checklist

Inspect - Oven cavity lamp	
Inspect - Oven cavity for signs of grease/carbon buildup	
Inspect - Loosen thumb screws to inspect behind the fan panel inside the oven cavity for signs of grease/carbon buildup	
Inspect - Loosen thumb screws to inspect behind the fan panel inside the oven cavity for signs of scale buildup	
<b>G</b> Inspect - The heat exchanger for any signs of major deformation. If yes, immediately remove from service and take corrective action steps.	
<b>G</b> Inspect - The heat exchanger for any loose/disconnected pipes or flanges. If yes, immediately remove from service and take corrective action steps.	
<b>E</b> Inspect - Convection elements for signs of cracking, deformation, or damage	
Clean ventless hood grease filters	
Employee initials	

**G** Gas units only

**E** Electric units only

### Component Malfunction and Replacement

List details of the failure(s) next to the day they occurred. Leave blank if components are working properly.	
Week 1	
Week 2	
Week 3	
Week 4	

# Inspection Checklist

## Monthly Inspection

### Unit Information

Business Name: \_\_\_\_\_

Serial Number: \_\_\_\_\_

Model Number: \_\_\_\_\_

Monthly Inspection Start Date: \_\_\_\_\_

### Monthly Inspection Checklist

Inspect/Test - Proper draining of the oven cavity	
Inspect - All drain lines for leaks or clogs	
<b>EB</b> Descale the steam generator	
Inspect - Oven cavity for any signs of scale buildup	
Descale the oven interior	
Inspect ventless hood paper filter (replace as needed)	
Test ventless hood drain for proper drainage and signs of leaking	
Employee initials	

**EB** Electric boiler units only

### Component Malfunction & Replacement

Summarize any component failure(s) that may have occurred during this month.

## Yearly Inspection

### Unit Information

**Business Name:** \_\_\_\_\_

**Serial Number:** \_\_\_\_\_

**Model Number:** \_\_\_\_\_

**12-Month Inspection Start Date:** \_\_\_\_\_

### 12-Month Inspection Checklist

Replace - Steam bypass hose	
Inspect - Cleaning pump hose	
Inspect/Test - Proper draining of the oven cavity	
Inspect - All drain lines for leaks or clogs	
Inspect - All solenoid hoses (both ends)	
Inspect - Upper browning valve hose	
Inspect - Low pressure relief valve & hose	
<b>E</b> Inspect - Convection element seal (from the electrical compartment)	
<b>G</b> Inspect - Gas heat exchanger seal (from the electrical compartment)	
Inspect - N6 oven temperature probe seal	
<b>EB</b> Descale the steam generator	
<b>EB</b> Remove & Inspect - Steam generator elements	
Inspect - Hand shower hose	
Inspect - Hand shower handle	
Inspect - Product probe	
Inspect - Water injection tube	
Inspect - Oven cavity for any signs of scale buildup	
Inspect - Oven cavity lamp	
Inspect - Oven cavity for signs of grease/carbon buildup	
Inspect - Behind the fan panel inside the oven cavity for signs of grease/carbon buildup	
Inspect - Behind the fan panel inside the oven cavity for signs of scale buildup	

**EB** Electric boiler units only    **G** Gas units only    **E** Electric units only

# Inspection Checklist

## Unit Information

**Business Name:** \_\_\_\_\_

**Serial Number:** \_\_\_\_\_

**Model Number:** \_\_\_\_\_

**12-Month Inspection Start Date:** \_\_\_\_\_

## 12-Month Inspection Checklist

<b>G</b> Inspect - The heat exchanger for any signs of major deformation. If yes, immediately remove from service and take corrective action steps.	
<b>G</b> Inspect - The heat exchanger for any loose/disconnected pipes or flanges. If yes, immediately remove from service and take corrective action steps.	
<b>G</b> Inspect and Ensure - Exhaust pipes are exiting the oven cavity	
<b>G</b> Inspect - Heat exchanger flange gasket (replace as needed)	
<b>G</b> Inspect and Tighten - Heat exchanger flange bolts	
<b>G</b> Inspect and Tighten - Heat exchanger burner flange hardware & gasket (replace as needed)	
<b>G</b> Inspect and Tighten - Heat exchanger igniter flange hardware & gasket (replace as needed)	
<b>G</b> Inspect - Heat exchanger exhaust pipes (ensure they are exiting out past the oven cavity ceiling flange) - ESG models only	
<b>G</b> Inspect - Oven cavity ceiling flange & flange gasket - ESG models only	
<b>G</b> Tighten - Burner flange bolts	
<b>G</b> Tighten - Igniter flange bolts	
Inspect - Heat exchanger weep holes to ensure they are free of obstructions (if the hole is obstructed, immediately remove oven from service and replace the heat exchanger)	
<b>E</b> Inspect - Convection elements for signs of cracking, deformation, or damage	
Replace - Oven lamp cover(s) & gasket(s)	
Descale the oven interior	
Inspect - Upper and lower door hinges and pins	
Inspect - Door gasket (replace as needed)	
Inspect - Door upper and lower hinges (replace as needed)	
Wipe the inner door glass	
Inspect - Front drip tray (clean as needed)	
Inspect - Front drip tray hose	
Inspect - Control overlay	
Inspect and Tighten - All electrical connections	
Inspect and Tighten - All cooling fans for proper operation	

**EB** Electric boiler units only    **G** Gas units only    **E** Electric units only

**Unit Information**

**Business Name:** \_\_\_\_\_

**Serial Number:** \_\_\_\_\_

**Model Number:** \_\_\_\_\_

**12-Month Inspection Start Date:** \_\_\_\_\_

**12-Month Inspection Checklist**

Inspect and Tighten - Door hinges and lower hinge pin bolt	
Inspect and Tighten - Door handle	
If there is a smoker, inspect the smoke element for visual signs of deformation, cracks or breaks (replace as needed)	
Review - Error code history	
Note the software version (update if not current)	
Record - Water pressure (static & dynamic)	
Record - Line voltage across all lines	
Record - Line voltage to ground on each line	
Record - Amperage across all three legs (when heating)	
Function test all components (list components)	
For ovens shipped to New Zealand or Australia, inspect the backflow preventer check valve per AS/NZ3500.1 and AS/NZ3500.2	

**Component Failure and Replacement**

Summarize any component failure(s) that may have occurred during this month.

**Customer Signature:** \_\_\_\_\_

**Technician Signature:** \_\_\_\_\_

## Error Codes

ALWAYS verify the circuit breaker is turned “ON” and your unit is receiving power BEFORE calling your Authorized Alto-Shaam Service Agent.

### NOTICE

This section is provided for the assistance of qualified and trained service technicians only and is not intended for use by untrained or unauthorized service personnel. Do not attempt to repair or service the oven beyond this point. Contact Alto-Shaam for the nearest authorized service agent. Repairs made by any other service agents without prior authorization by Alto-Shaam will void the warranty.

When the oven malfunctions, an error code will appear in the display.



**Press the Start icon to acknowledge the error.**

When the oven error notification has been acknowledged, the Combitherm will attempt to return to normal operation.

Error Code	Error Call Out in Display	Description of Error	Possible Cause(s) and Remedies
<b>E01</b>	Low Water steam generators	Applies only to roll-in models.  Low water level in steam generator (boiler).  Upper water level probe B1 is not satisfied within 5 minutes, after water solenoid valve Y1 is activated.	<ul style="list-style-type: none"> <li>— Water supply is shut off.</li> <li>— Water pressure is low.</li> <li>— Water-level probe (B1) has calcium build-up.</li> <li>— Fill-water solenoid valve (Y1) has malfunctioned.</li> <li>— Drain pump elbow is leaking.</li> <li>— Steam generator drain cap is missing.</li> <li>— Steam generator drain pump has malfunctioned.</li> <li>— Drain pump elbow leaking.</li> <li>— Relay board has malfunctioned.</li> </ul>
<b>E02</b>	Control Temperature High	Relay board temperature is higher than 176°F (80°C).	<ul style="list-style-type: none"> <li>— Cooling fan has malfunctioned.</li> <li>— Cooling fan air intake blocked.</li> </ul>
<b>E03</b>	Fan Motor Error	Applies to table-top models and upper fan motors on roll-in models.  Convection fan motor does not spin after 60 seconds. Detected by the Hall Effect sensor.	<ul style="list-style-type: none"> <li>— Motor or fan wheel locked.</li> <li>— If LED on motor control flashes, see error codes for motor control.</li> <li>— Hall Effect sensor does not detect motor rotation.</li> </ul>
<b>E04</b>	Lower Fan Motor Error	Applies only to roll-in models.  Lower convection fan motor does not spin after 60 seconds. Detected by the Hall Effect sensor.	<ul style="list-style-type: none"> <li>— Motor or fan wheel locked.</li> <li>— If LED on motor control flashes, see error codes for motor control.</li> <li>— Hall Effect sensor does not detect motor rotation.</li> </ul>
<b>E05</b>	VFD Comm Failure	Applies to table-top models and upper VFDs on roll-in models  Communication error when VFD does not respond to a query on the CAN interface.	<ul style="list-style-type: none"> <li>— Loss of power to VFD.</li> <li>— CAN cable disconnected.</li> <li>— VFD has malfunctioned.</li> <li>— Control board has malfunctioned.</li> </ul>
<b>E06</b>	Lower VFD Comm Failure	Applies only to roll-in models.  Communication error when VFD does not respond to a query on the CAN interface.	<ul style="list-style-type: none"> <li>— Loss of power to VFD.</li> <li>— CAN cable disconnected.</li> <li>— VFD has malfunctioned.</li> <li>— Control board has malfunctioned.</li> </ul>

## Error Codes

Error Code	Error Call Out in Display	Description of Error	Possible Cause(s) and Remedies
<b>E07</b>	Error Received from VFD	Applies to table-top models and upper VFDs on roll-in models.  When VFD is flashing the green light.	— Refer to VFD error code list and match to number of blinks on the green LED of VFD.
<b>E08</b>	Error Received from Lower VFD	Applies only to roll-in models.  When VFD is flashing the green light	— Refer to VFD error code list and match to number of blinks on the green LED of VFD.
<b>E11</b>	Convection Temperature High	In Combination program, cavity temperature N6 is measuring in excess of 600°F (315°C) for a minimum of 25 seconds.  In Convection program, cavity temperature probe (N6) is measuring in excess of 600°F (315°C) for a minimum of 25 seconds.	— Convection element contactor locked/on. — Oven cavity temperature probe (N6) has malfunctioned.
<b>E13</b>	Steam generator temperature High	Steam generator temperature is more than 248°F (120°C) for more than 25 seconds, detected by probe (B4).	— Calcium build-up on water level probe. — Calcium build-up in steam generator. — Steam element contactor locked/on. — Boiler temperature probe (B4) has malfunctioned.
<b>E15</b>	Condensor Temperature High	Condensor-water temperature is more than 212°F (100°C) for more than 180 seconds, detected by B3 probe (B4).	— Water supply is shut off. — Plugged steam bypass hose. — Miswired condensor temperature probe (B3). — Condensor temperature probe (B3) has malfunctioned. — Cooling-water-solenoid valve (Y2) has malfunctioned.
<b>E20</b>	B11 Core Temperature Probe Single Point Fault	Single-point core-temperature probe malfunctioning or disconnected.	— Core-temperature probe (B11) not inserted into food correctly. — Core-temperature probe (B11) not connected to oven. — Clean probe receptacle pins with sandpaper if applicable. — Core-temperature probe (B11) has malfunctioned.
<b>E21</b>	N6 Cavity Probe Fault	Cavity-temperature probe malfunctioning or disconnected.	— Oven cavity temperature probe (N6) has malfunctioned. — Oven cavity temperature probe (N6) wires disconnected.
<b>E22</b>	B10 Core Temperature Probe Multi-point Fault	Multipoint core-temperature probe malfunctioned or disconnected.	— Multipoint core temperature probe (B10) malfunctioned. — Multipoint core temperature probe (B10) wires disconnected.
<b>E23</b>	B4 Steam Generator Probe Fault	Steam-generator temperature probe malfunctioned or disconnected.	— Boiler temperature probe (B4) has malfunctioned. — Boiler temperature probe (B4) miswired.
<b>E24</b>	B5 Bypass Probe Fault	Bypass steam-temperature probe malfunctioned or disconnected.	— Bypass steam temperature probe (B5) has malfunctioned. — Bypass steam temperature probe (B5) miswired.
<b>E25</b>	B3 Condensor Probe Fault	Condensor-water-temperature probe malfunctioned or disconnected.	— Condensor temperature probe (B3) has malfunctioned. — Condensor probe (B3) miswired.
<b>E26</b>	B10 - Point 1 - Core Temperature Probe Multipoint Fault	Multipoint core-temperature probe malfunctioned or disconnected.	— Multipoint core-temperature probe (B10) malfunctioned. — Multipoint core-temperature probe (B10) miswired.
<b>E27</b>	B10 - Point 2 - Core Temperature Probe Multipoint Fault	Multipoint core-temperature probe malfunctioned or disconnected.	— Multipoint core-temperature probe (B10) malfunctioned. — Multipoint core-temperature probe (B10) miswired.

# Troubleshooting – Error Codes

## Error Codes

Error Code	Error Call Out in Display	Description of Error	Possible Cause(s) and Remedies
<b>E28</b>	B10 - Point 3 - Core Temperature Probe Multipoint Fault	Multipoint core-temperature probe malfunctioned or disconnected.	<ul style="list-style-type: none"> <li>— Multipoint core-temperature probe (B10) malfunctioned.</li> <li>— Multipoint core-temperature probe (B10) wires disconnected.</li> </ul>
<b>E29</b>	B10 - Point 4 - Core Temperature Probe Multipoint Fault	Multipoint core-temperature probe malfunctioned or disconnected.	<ul style="list-style-type: none"> <li>— Multipoint core-temperature probe (B10) defective.</li> <li>— Multipoint core-temperature probe (B10) wires disconnected.</li> </ul>
<b>E34</b>	Steam Generator Drain Pump Fault	If water level does not drop below lower water level probe after three minutes when steam generator drain pump is activated in cleaning program.	<ul style="list-style-type: none"> <li>— Calcium build-up or blockage in steam generator drain pump.</li> <li>— Boiler drain pump has malfunctioned.</li> <li>— Water-level probe has malfunctioned.</li> </ul>
<b>E36</b>	Steam Temperature High	<p>In Steam program, cavity temperature probe N6 is measuring in excess of 395°F (200°C) for more than 60 seconds.</p> <p>In Combination program, cavity temperature probe N6 is measuring in excess of 600°F (315°C), for more than 60 seconds.</p> <p>In Retherm program, cavity temperature probe N6 is measuring in excess of 395°F (200°C), for more than 60 seconds.</p> <p>In Cleaning program, cavity temperature probe N6 is measuring in excess of 395°F (200°C), for more than 60 seconds.</p>	<ul style="list-style-type: none"> <li>— Water supply is shut off.</li> <li>— Water pressure is low.</li> <li>— Calcium build-up on water injection pipe.</li> <li>— Water flow restrictor has malfunctioned or has calcium build-up.</li> <li>— Water solenoid valve (Y1) has malfunctioned.</li> <li>— Steam by-pass hose blocked.</li> </ul>
<b>E40</b>	B3 Fault	B3 probe shorted to ground.	— Probe (B3) miswired probe or has malfunctioned.
<b>E41</b>	B4 Fault	B4 probe shorted to ground.	— Probe (B4) miswired probe or has malfunctioned.
<b>E42</b>	B5 Fault	B5 probe shorted to ground.	— Probe (B5) miswired probe or has malfunctioned.
<b>E43</b>	N6 Fault	N6 probe shorted to ground.	— Probe (N6) miswired probe or has malfunctioned.
<b>E44</b>	N8 Fault	N8 probe shorted to ground.	— Probe (N8) miswired probe or has malfunctioned.
<b>E45</b>	B10 Fault	B10 probe shorted to ground.	— Probe (B10) miswired probe or has malfunctioned.
<b>E46</b>	B10 - Point 1 Fault	B10 probe shorted to ground.	— Probe (B10) miswired probe or has malfunctioned.
<b>E47</b>	B10 - Point 2 Fault	B10 probe shorted to ground.	— Probe (B10) miswired probe or has malfunctioned.
<b>E48</b>	B10 - Point 3 Fault	B10 probe shorted to ground.	— Probe (B10) miswired probe or has malfunctioned.
<b>E49</b>	B10 - Point 4 Fault	B10 probe shorted to ground.	— Probe (B10) miswired probe or has malfunctioned.
<b>E51</b>	No Water in Steam Generator	<p>Applies only to roll-in models.</p> <p>Lower-water-level probe (B2) does not detect water within 5 minutes after water-solenoid-valve (Y1) is activated.</p>	<ul style="list-style-type: none"> <li>— Water supply is shut off.</li> <li>— Water pressure is low.</li> <li>— Water-level probe (B1) has calcium build-up.</li> <li>— Fill-water solenoid valve (Y1) has malfunctioned.</li> <li>— Drain pump elbow is leaking.</li> <li>— Steam generator drain cap is missing.</li> <li>— Steam generator drain pump has malfunctioned.</li> <li>— Drain pump elbow leaking.</li> <li>— Relay board has malfunctioned.</li> </ul>
<b>E53</b>	Fan Motor High Temperatures	<p>Applies to table-top models and upper fan motors on roll-in models.</p> <p>Fan motor does not spin, resulting in overheating. Detected by motor coil safety thermo element. Temperature is above 320°F (160°C).</p>	<ul style="list-style-type: none"> <li>— Motor high limit open or wired incorrectly.</li> <li>— If LED on motor control flashes, see error codes for motor control.</li> <li>— Motor or fan wheel locked.</li> <li>— Fan wheel damaged.</li> </ul>
<b>E54</b>	Lower Fan-Motor High Temperature	<p>Applies only to roll-in models.</p> <p>Lower fan motor does not spin, resulting in overheating. Detected by motor coil safety thermo element. Temperature is above 320°F (160°C).</p>	<ul style="list-style-type: none"> <li>— Motor or fan wheel locked.</li> <li>— If LED on motor control flashes, see error codes for motor control.</li> <li>— Motor high limit open or wired incorrectly.</li> </ul>

## Error Codes

Error Code	Error Call Out in Display	Description of Error	Possible Cause(s) and Remedies
<b>E55</b>	Vent Not Open	Applies to single-vent models and to lower vent on dual-vent models.  60 seconds after the venting motor is activated, the vent-motor monitoring switch did not open.	<ul style="list-style-type: none"> <li>— Vent valve monitoring switch has malfunctioned.</li> <li>— Vent valve (motor) has malfunctioned.</li> </ul>
<b>E56</b>	Vent 2 Not Open	Upper vent on dual-vent models  60 seconds after the venting motor is activated, the vent motor monitoring switch did not open.	<ul style="list-style-type: none"> <li>— Vent valve monitoring switch has malfunctioned.</li> <li>— Vent valve (motor) has malfunctioned.</li> </ul>
<b>E57</b>	No Rinse Water	Flow switch for solenoid valve (Y4) does not detect any water flow for a minimum of 60 seconds.	<ul style="list-style-type: none"> <li>— Water supply is shut off.</li> <li>— Water pressure is low.</li> <li>— Flow switch is dirty or has malfunctioned.</li> </ul>
<b>E88</b>	Gas Ignition Failure  NOTE: If after 2 attempts to clear this error, the error appears a third time, remove the oven from service and immediately contact an Alto-Shaam authorized service provider.	Burner has failed to ignite.	Refer to detailed procedure titled “No Combustion on a Call for Heat” following these error codes.
<b>E89</b>	Upper Gas Ignition Failure  NOTE: If after 2 attempts to clear this error, the error appears a third time, remove the oven from service and immediately contact an Alto-Shaam authorized service provider.	Applies to table-top models and upper igniters on roll-in models.  Reset output from Ignition Module is ON	<ul style="list-style-type: none"> <li>— Gas supply is shut off.</li> <li>— Gas supply is low.</li> <li>— Hot surface ignitor has malfunctioned.</li> <li>— Flame sensor has malfunctioned.</li> <li>— Heat exchanger is plugged.</li> <li>— Ignition control has malfunctioned.</li> <li>— Gas valve has malfunctioned.</li> </ul> Refer to Troubleshooting
<b>E90</b>	Lower Gas Combustion Blower Not at Speed	Applies only to roll-in models.  Speed is too slow.	<ul style="list-style-type: none"> <li>— Power supply cable is not connected to combustion blower motor.</li> <li>— Speed control cable is not connected to combustion blower motor.</li> <li>— Combustion blower motor is blocked, rotation is impeded, or motor has malfunctioned.</li> <li>— Faulty control board.</li> </ul>
<b>E91</b>	Upper Gas Blower Not at Speed	Table-top models or upper blowers on roll-in models.  Speed is too slow.	<ul style="list-style-type: none"> <li>— Power supply cable is not connected to combustion blower motor.</li> <li>— Speed control cable is not connected to combustion blower motor.</li> <li>— Combustion blower motor is blocked, rotation is impeded, or motor has malfunctioned.</li> <li>— Faulty control board.</li> </ul>
<b>E92</b>	Communication Error CB does not properly respond	No response from the Control Board (CB) to the Interface Board (IB).	<ul style="list-style-type: none"> <li>— Turn off oven. Disconnect power. Reconnect power. Turn oven on.</li> <li>— Check CAN cable connections between CB and IB.</li> <li>— CAN cable has malfunctioned.</li> <li>— Relay board, low voltage, connector defective.</li> <li>— Display board connector defective.</li> </ul>
<b>E93</b>	Interface Board (IB) and Control Board (CB) are in different states	The IB is in a different running state than the CB for more than 20 seconds.	<ul style="list-style-type: none"> <li>— Turn off oven. Disconnect power. Reconnect power. Turn oven on.</li> <li>— Check CAN cable connections between CB and IB.</li> <li>— CAN cable has malfunctioned.</li> <li>— Relay board, low voltage, connector defective.</li> <li>— Display board connector defective.</li> </ul>
<b>E94</b>	Communication Error, TO Interface Board	No signal transfer for more than 20 seconds between the Interface Board (IB) and the Control Board (CB).	<ul style="list-style-type: none"> <li>— Turn off oven. Disconnect power. Reconnect power. Turn oven on.</li> <li>— Check CAN cable connections.</li> <li>— CAN cable defective.</li> <li>— Relay board, low voltage, connector defective.</li> <li>— Display board connector defective.</li> </ul>

## Error Codes

Error Code	Error Call Out in Display	Description of Error	Possible Cause(s) and Remedies
<b>E100</b>	One or more maintenance reminder has timed out.	When any maintenance reminder has expired without action having been taken by the operator.	— Enter maintenance reminder screen and address the item that has timed out and reset.
<b>E101</b>	Ventless Hood Fault - No Pressure	If the power switch or pressure switch is not closed.	<ul style="list-style-type: none"> <li>— Check if filters are installed.</li> <li>— Check if filters are clogged.</li> <li>— Check operation of hood fan.</li> <li>— Check filter switch for proper operation.</li> <li>— Check pressure switch for proper operation.</li> </ul>
<b>E102</b>	Ventless Hood Fault — Filters Not Present	If the air filter switches are not closed.	<ul style="list-style-type: none"> <li>— Check if filters are installed.</li> <li>— Check if filters are clogged.</li> <li>— Check operation of hood fan.</li> <li>— Check filter switch for proper operation.</li> <li>— Check pressure switch for proper operation.</li> </ul>
<b>E103</b>	Option Board Doesn't Send Switch Setting	Option Board (OB) not communicating with Control Board (CB).	<ul style="list-style-type: none"> <li>— Check CAN cable connection between OB and CB.</li> <li>— Ensure CB dip switch is set to see an OB (ON position).</li> <li>— Incompatible OB and CB software (update software).</li> <li>— OB has malfunctioned.</li> <li>— CB has malfunctioned.</li> </ul>
<b>E104</b>	Option Board Not Communicating	Option Board (OB) not communicating with Control Board (CB).	<ul style="list-style-type: none"> <li>— Check CAN cable connection between OB and CB.</li> <li>— Ensure CB dip switch is set to see an OB (ON position).</li> <li>— Incompatible OB and CB software (update software).</li> <li>— OB has malfunctioned.</li> <li>— CB has malfunctioned.</li> </ul>
<b>E105</b>	No or Low Water Pressure	Water pressure switch not activated.	<ul style="list-style-type: none"> <li>— Water supply not connected.</li> <li>— Water supply is shut off.</li> <li>— Water supply to unit blocked or obstructed (check filter).</li> </ul>
<b>E108</b>	Cooling Fan Failure	If the temperature on the control board (relay board) is greater than 140°F (60°C) and less than 176°F (80°C). (See error code E02.)	<ul style="list-style-type: none"> <li>— Cooling fan has malfunctioned.</li> <li>— Cooling fan air intake blocked.</li> </ul>
<b>E109</b>	High Limit Switch  Press the high-limit reset switch only once. If the condition remains, contact Alto-Shaam service provider.	The High Limit Switch input to the CB (N7) is "open".	<ul style="list-style-type: none"> <li>— Unit has experienced an overheat condition.</li> <li>— Cooling fan has malfunctioned.</li> <li>— Heat relay is stuck closed.</li> <li>— Connection between high limit switch and Control Board (CB) is faulty.</li> <li>— High limit switch has malfunctioned.</li> </ul>
<b>E200</b>	The SD card has been detected to be larger than 2GB in size.	The SD card inserted is larger than 2GB in size.	— SD card is larger than 2GB in size. Contact service to order replacement SD card.
<b>E210</b>	VFD Under Voltage	Applies to table top and upper VFDs on roll-in models. VFD is in an under-voltage condition.	— Possible VFD malfunction.
<b>E211</b>	VFD Over Voltage	Applies to table top and upper VFDs on roll-in models. VFD is in an over-voltage condition.	— Possible VFD malfunction.
<b>E212</b>	VFD Overheating	Applies to table top and upper VFDs on roll-in models.  VFD is in an overheat condition.	<ul style="list-style-type: none"> <li>— Cooling fan has malfunctioned.</li> <li>— Cooling fan air intake blocked.</li> <li>— High-limit switch has malfunctioned.</li> <li>— Cooling fans damaged.</li> <li>— Possible VFD failure.</li> </ul>

## Touch Motor Control Error Codes

The LED is located on the variable frequency drive (VFD) ① of the oven.

Type of Error	Indication	Cause of Error
<b>Undervoltage</b>	LED flashing sequence, with 1 flash per period.	Voltage of intermediate circuit is less than 250V.
<b>Overvoltage</b>	LED flashing sequence, with 2 flashes per period.	Voltage of intermediate circuit exceeds 445V.
<b>Excess Temperature</b>	LED flashing sequence, with 3 flashes per period.	Temperature sensor in the power unit is more than 199°F (93°C).
<b>Current Peak</b>	LED flashing sequence, with 4 flashes per period.	Blocked motor, detected by current peak monitoring from 900 rpm rotating field.
<b>Overcurrent</b>	LED flashing sequence, with 5 flashes per period.	Intermediate circuit current exceeds 4.0A.
<b>Short-circuit</b>	LED flashing sequence, with 6 flashes per period.	Release of interrupt at intermediate circuit current larger than 53.0A.
<b>Power on</b>	LED flashing sequence, with 7 flashes per period.	Effective mains voltage does not correspond to jumper setting 115V/230V.
<b>Watchdog</b>	LED flashing sequence, with 8 flashes per period.	Watchdog of the microcontroller released, program crash.

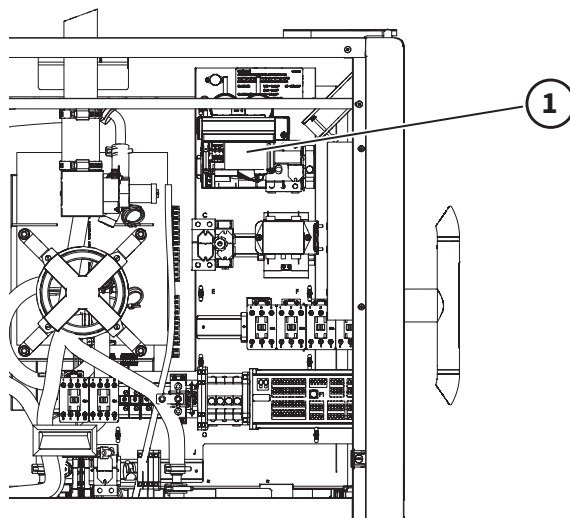

Maintenance Codes	
1001	Descale steam generator.
1002	Check water filter.
1003	Cleaning is past due.
1004	Check ventless hood filter.
1005	Inspect door gasket.











# ALTO-SHAAM.

Menomonee Falls, WI U.S.A.

Phone 800-558-8744 | +1-262-251-3800 | [alto-shaam.com](http://alto-shaam.com)

## ASIA

Shanghai, China  
Phone +86-21-6173-0336

## AUSTRALIA

Brisbane, Queensland  
Phone 800-558-8744

## CANADA

Concord, Ontario Canada  
Toll Free Phone 866-577-4484  
Phone +1-905-660-6781

## FRANCE

Aix en Provence, France  
Phone +33(0)4-88-78-21-73

## GMBH

Bochum, Germany  
Phone +49 [0]234 298798-0

## ITALY

Padua, Italy  
Phone +39 3476073504

## INDIA

Pune, India  
Phone +91 9657516999

## MEXICO

Phone +52 1 477-717-3108

## MIDDLE EAST & AFRICA

Dubai, UAE  
Phone +971-4-321-9712

## CENTRAL & SOUTH AMERICA

Miami, FL USA  
Phone +1 954-655-5727

## RUSSIA

Moscow, Russia  
Phone +7 903 7932331