



Migali®

PROJECT:	_____
LOCATION:	_____
ITEM#:	_____
QUANTITY:	_____

COMPETITOR SERIES®



C-CM-36-LP/NG

CHEESE MELTER

- Stainless steel exterior and interior
- Dual valve controls for left and right-side independent operation
- Two (2) 21,500 BTU high efficiency ceramic infrared burners and standby pilots – totals 43,000 BTU's
- Removable broiler rack and crumb catcher
- Range mount kit available to fit 36" wide range
- Manual ignition of burners
- Natural gas or liquid propane configuration
- Migali Industries® Protection Plan: 2 Years Parts & Labor Warranty

MODEL	BURNERS	GAS SPECS	IN TAKE TUBE PRESSURE (IN W.C.)	BTU PER BURNER	TOTAL BTU	NOZZLE NO.	CONTROL METHOD	EXTERIOR DIMENSIONS W X D X H	INTERIOR DIMENSIONS W X D X H	PACKAGED DIMENSIONS W X D X H	WEIGHT	PACKAGED WEIGHT
C-CM36-NG	2	NG	5	21,500	43,000	NG47	Independent Manual Control	36" x 18" x 17.3"	31.5" x 15.5" x 8.3"	40" x 24.6" x 25.4"	95 lbs.	120 lbs.
C-CM36-LP	2	LP	10	21,500	43,000	LP54	Independent Manual Control	36" x 18" x 17.3"	31.5" x 15.5" x 8.3"	40" x 24.6" x 25.4"	95 lbs.	120 lbs.

*MIGALI RESERVES THE RIGHT TO CHANGE SPECIFICATIONS WITHOUT NOTICE



TOLL FREE: 800.852.5292
WEB: www.migali.com



Conforms to ANSI STD Z83
11a-2009 (2011), NSF/ANSI STD 4
& CSA STD 1-8b-2009(2011)



DIMENSIONAL DRAWINGS

C-CM-36-NG/LP

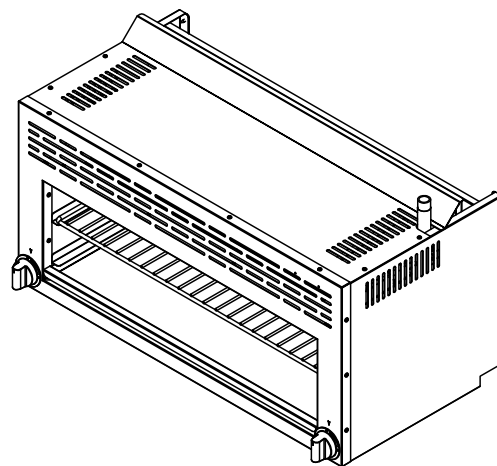
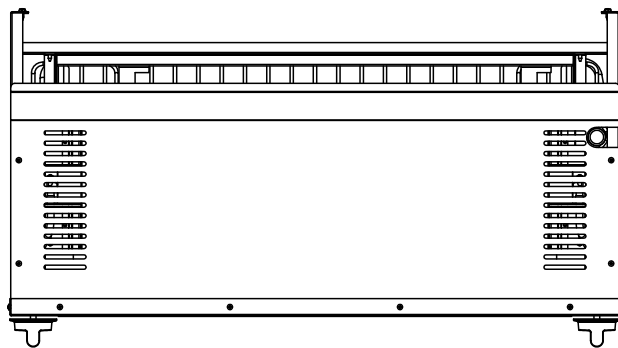
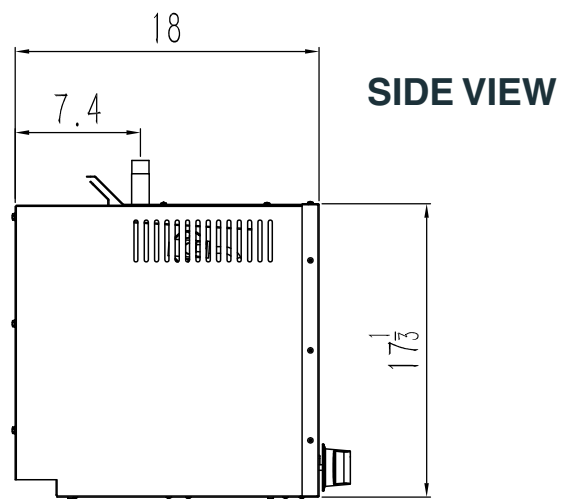
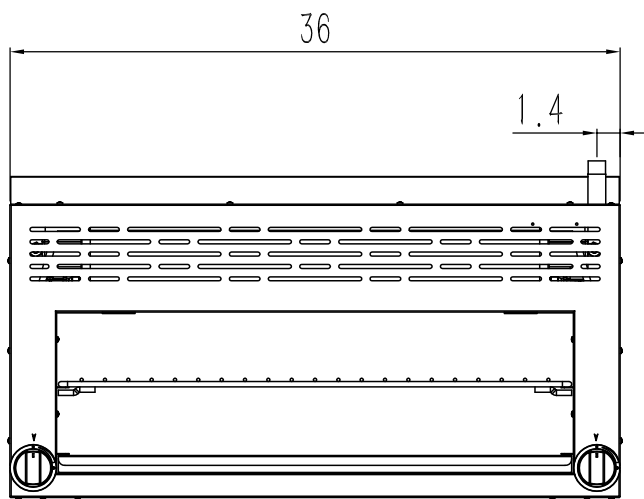

MIGALI® REMAINS AN AMERICAN FAMILY COMPANY SINCE 1955